

YAMAHA

PARTS CATALOGUE

Initial Serial No. and Color Code

YZ125B (3XJ2) 1991 '91

(A) Frame Serial No.	3XJ-008101 and following
(B) Engine Serial No.	3XJ-008101 and following

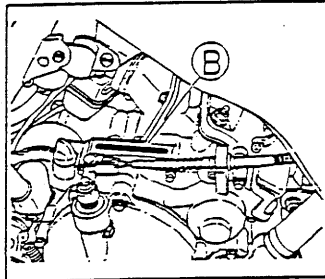
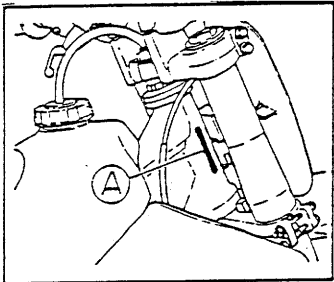

213XJ-100E1

Color Code	Color Name	Abbreviate
0206	PURPLISH WHITE SOLID 1	PWS1

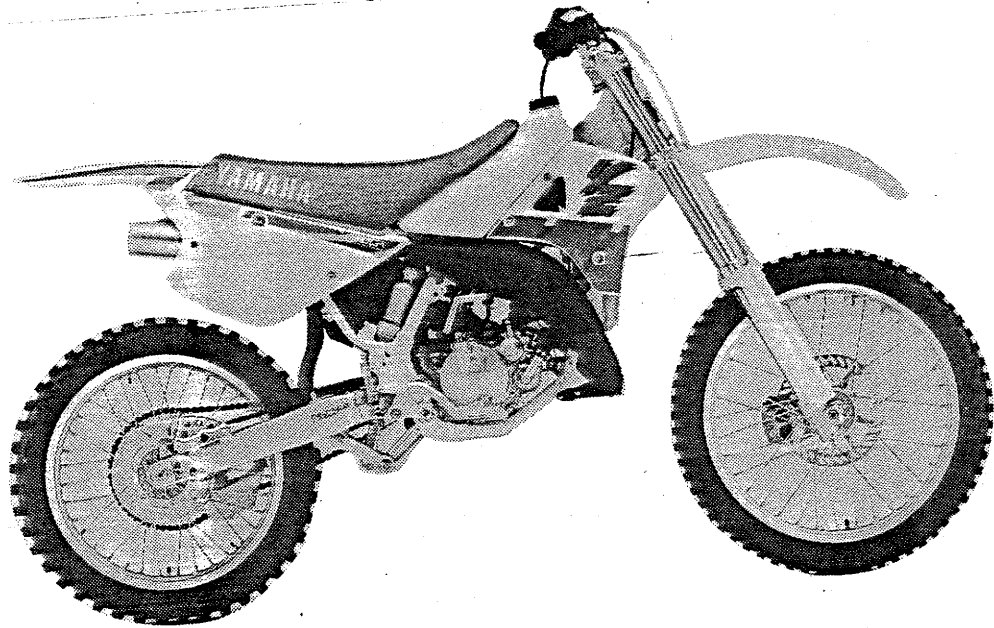

CONTENTS

ENGINE

	<u>BLOCK</u>
Cylinder Head	A-5,6
Governor	A-7
Crankshaft. Piston	A-8
Water Pump	A-9
Radiator. Hose	A-10
Intake	A-11
Carburetor	A-12, B-1
Exhaust	B-2
Crankcase	B-3
Crankcase Cover 1	B-4
Starter	B-5
Clutch	B-6,7
Transmission	B-8,9
Shift Cam. Fork	B-10
Shift Shaft	B-11

CHASSIS

Frame	B-12, C-1
Fender	C-2
Side Cover	C-3,4
Rear Arm	C-5,6
Rear Suspension	C-7
Steering	C-8
Front Fork	C-9,10,11
Fuel Tank	C-12
Seat	D-1
Front Wheel	D-2
Front Brake Caliper	D-3
Rear Wheel	D-4,5

	<u>BLOCK</u>
Rear Brake Caliper	D-6
Steering Handle. Cable	D-7
Front Master Cylinder	D-8
Stand. Footrest	D-9
Rear Master Cylinder	D-10
Generator	D-11
Handle Switch. Lever	D-12
Electrical 1	E-1

ALTERNATE PARTS

Alternate (Chassis)	E-2
---------------------------	-----

FIG. 1 CYLINDER HEAD

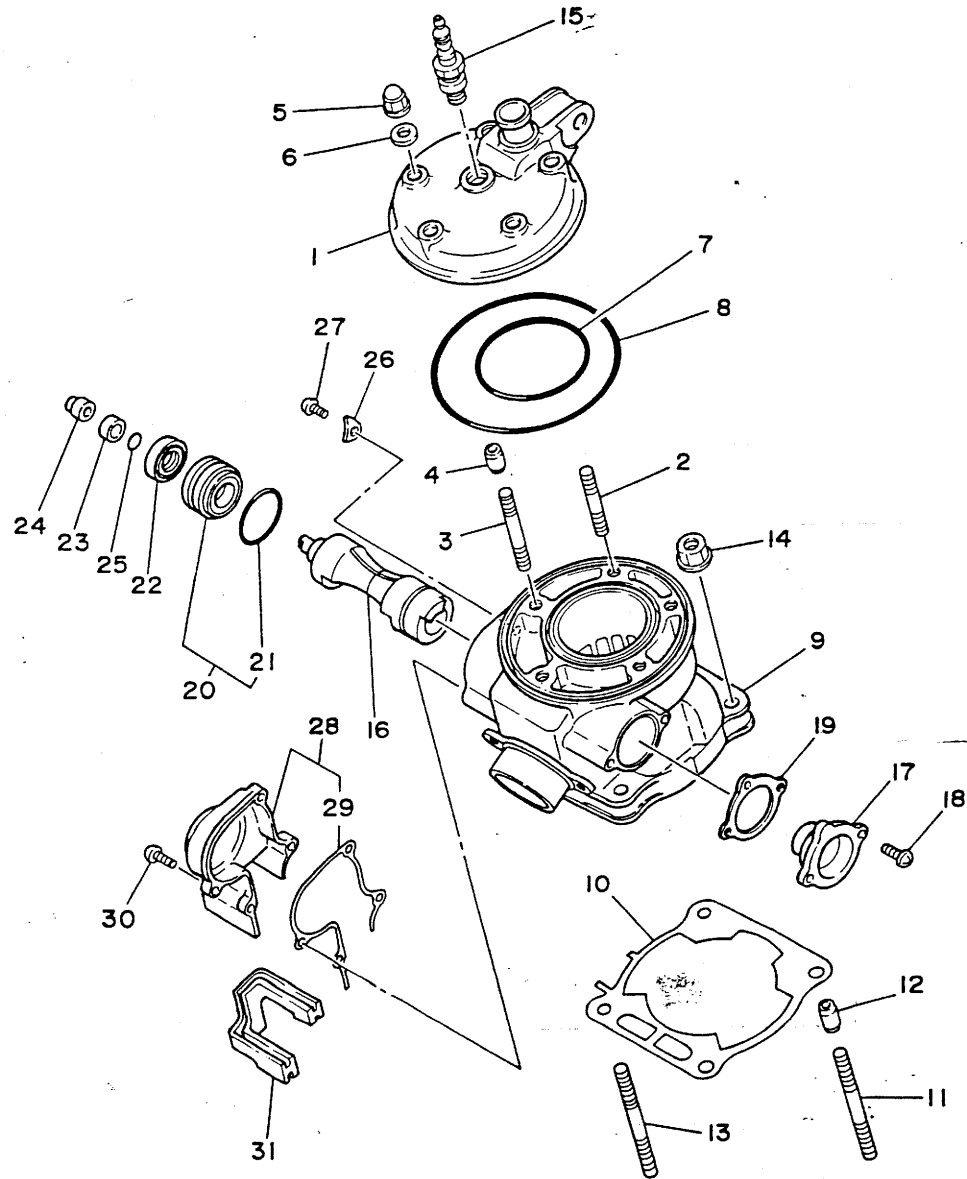

REF. NO.	PART NO.	DESCRIPTION	Q'TY	REMARKS
1	3XJ-11111-00	HEAD, cylinder 1	1	
2	90116-08394	BOLT, stud	3	
3	90116-08392	BOLT, stud	2	
4	99510-10114	PIN, dowel	2	
5	90176-08026	NUT, crown	5	
6	90201-08087	WASHER, plate	5	
7	93210-65721	O-RING	1	
8	93211-07720	O-RING	1	
9	3XJ-11311-00	CYLINDER 1	1	
10	1LX-11351-10	GASKET, cylinder	1	
11	90116-08388	BOLT, stud	2	
12	99510-10114	PIN, dowel	2	
13	90116-08533	BOLT, stud	2	
14	90179-08491	NUT	4	
15	BR9EG	PLUG, spark	1	
16	3XJ-1131A-00	VALVE 1	1	
17	3JE-W1132-00	HOLDER 1	1	
18	98501-05012	SCREW, pan head	2	
19	5X4-1131N-10	GASKET, holder	1	
20	2VN-Y113F-00	HOLDER 2 ASSY	1	
21	93210-270A8	.O-RING	1	
22	93104-16074	OIL SEAL	1	
23	90387-102W0	COLLAR	1	
24	3JE-11937-00	BOSS, lever	1	
25	93210-09192	O-RING	1	
26	47X-11915-00	PLATE, thrust 1	1	

FWD

FIG. 1 CYLINDER HEAD

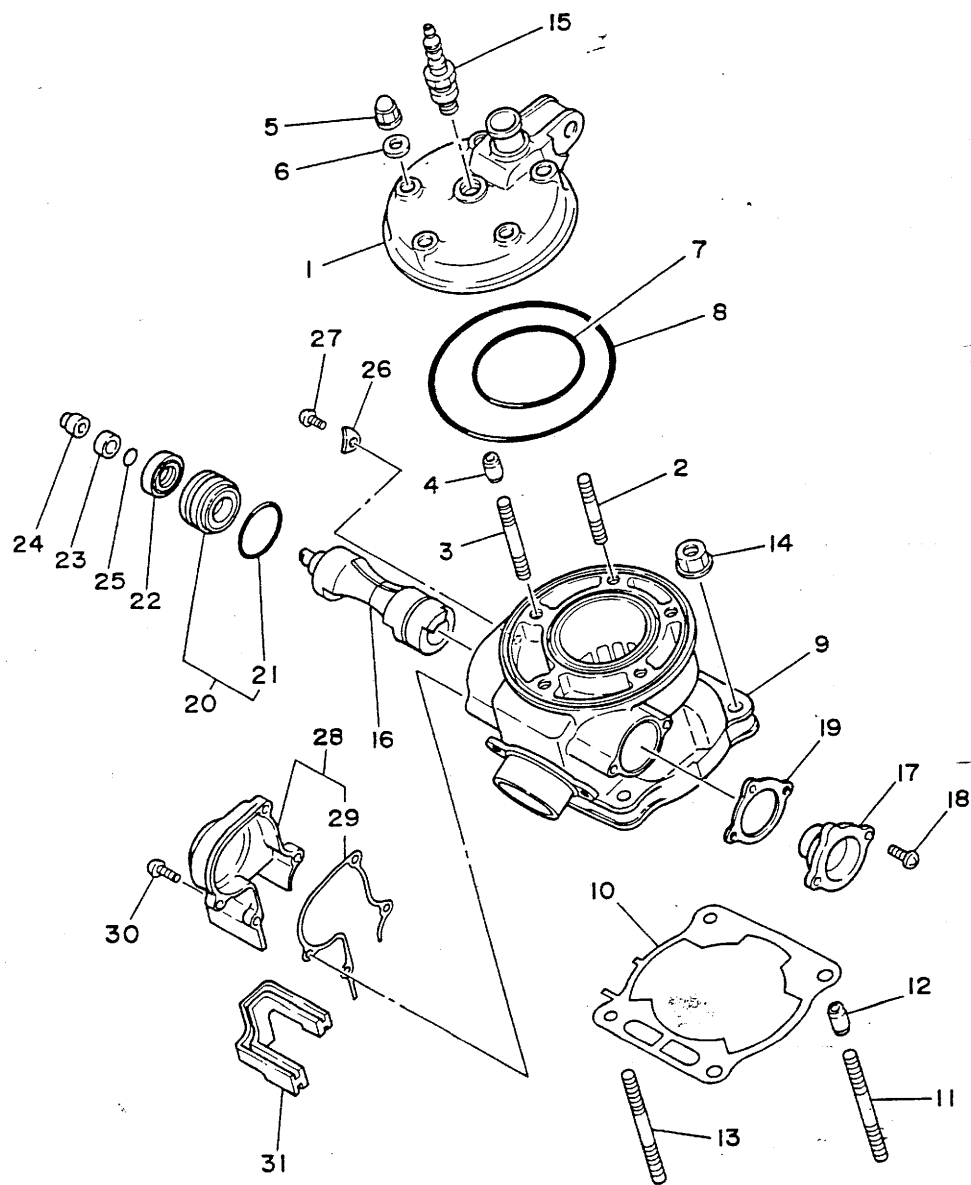

REF. NO.	PART NO.	DESCRIPTION	Q'TY	REMARKS
27	98506-05008	SCREW, pan head	1	
28	3JD-11992-10	HOUSING 2	1	
29	3JD-11993-10	.GASKET	1	
30	98501-05016	SCREW, pan head	4	
31	1LX-11995-01	SEAL, housing	1	

FIG. 2 GOVERNOR

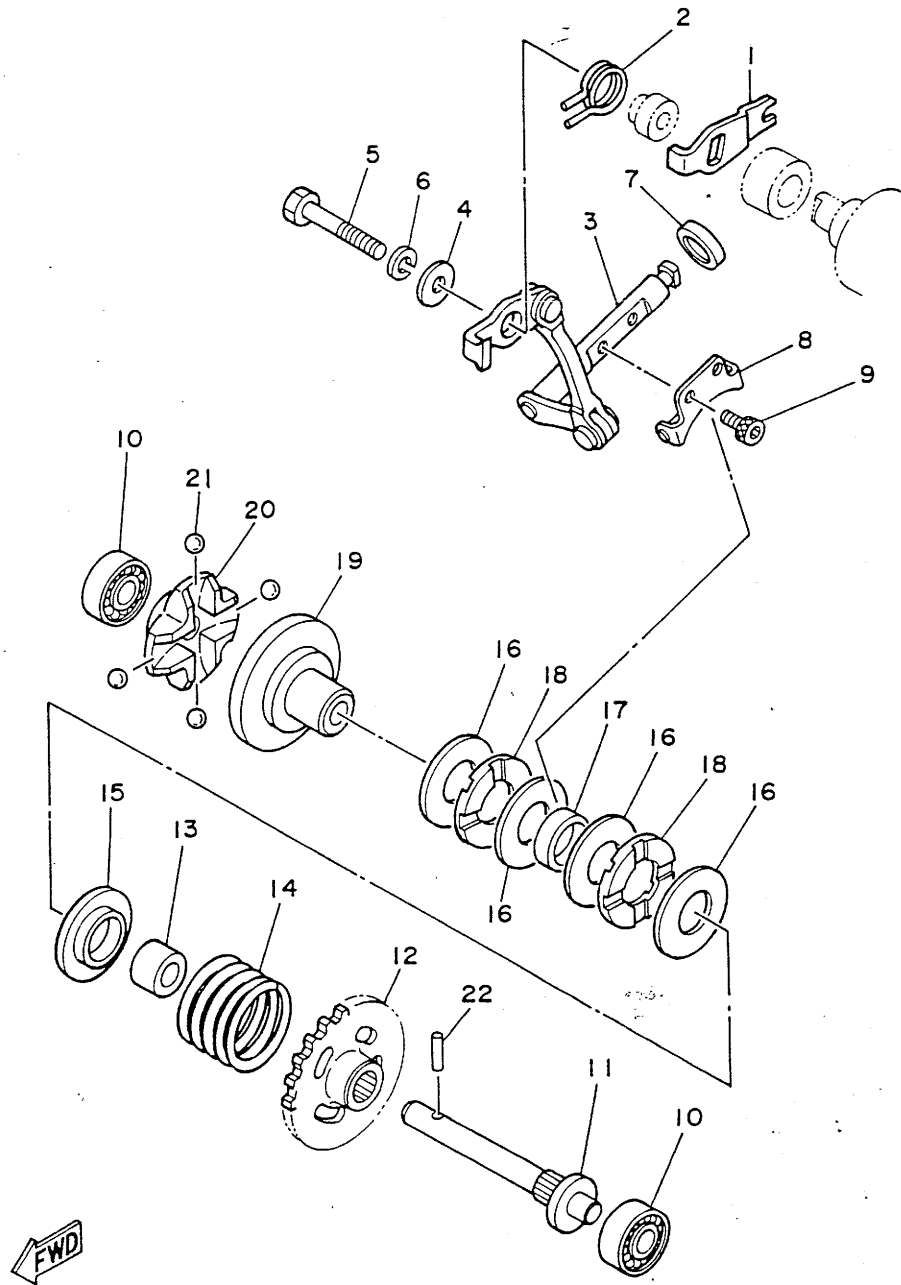

REF. NO.	PART NO.	DESCRIPTION	Q'TY	REMARKS
1	3JE-11931-00	LEVER	1	
2	90508-14783	SPRING, torsion	1	
3	3SR-11990-00	PUSH ROD ASSY	1	
4	90201-057H5	WASHER, plate	1	
5	97021-05030	BOLT	1	
6	92990-05100	WASHER, spring	1	
7	93104-08040	OIL SEAL	1	
8	5X4-11922-00	FORK, governor	1	
9	91316-04006	BOLT	2	
10	93300-60814	BEARING	2	
11	5X4-11921-02	SHAFT, governor	1	
12	3JD-11953-00	GEAR, governor	1	
13	90560-08213	SPACER	1	
14	90501-240E7	SPRING, compression	1	
15	5X4-11952-00	PLATE	1	
16	90201-154E9	WASHER, plate	4	
17	90387-152F2	COLLAR	1	
18	93340-21505	BEARING, thrust	2	
19	3XJ-11912-00	RETAINER, weight	1	
20	5X5-11911-01	RETAINER	1	
21	93521-64032	BALL	4	
22	93603-14179	PIN, dowel	1	

FIG. 3 CRANKSHAFT. PISTON

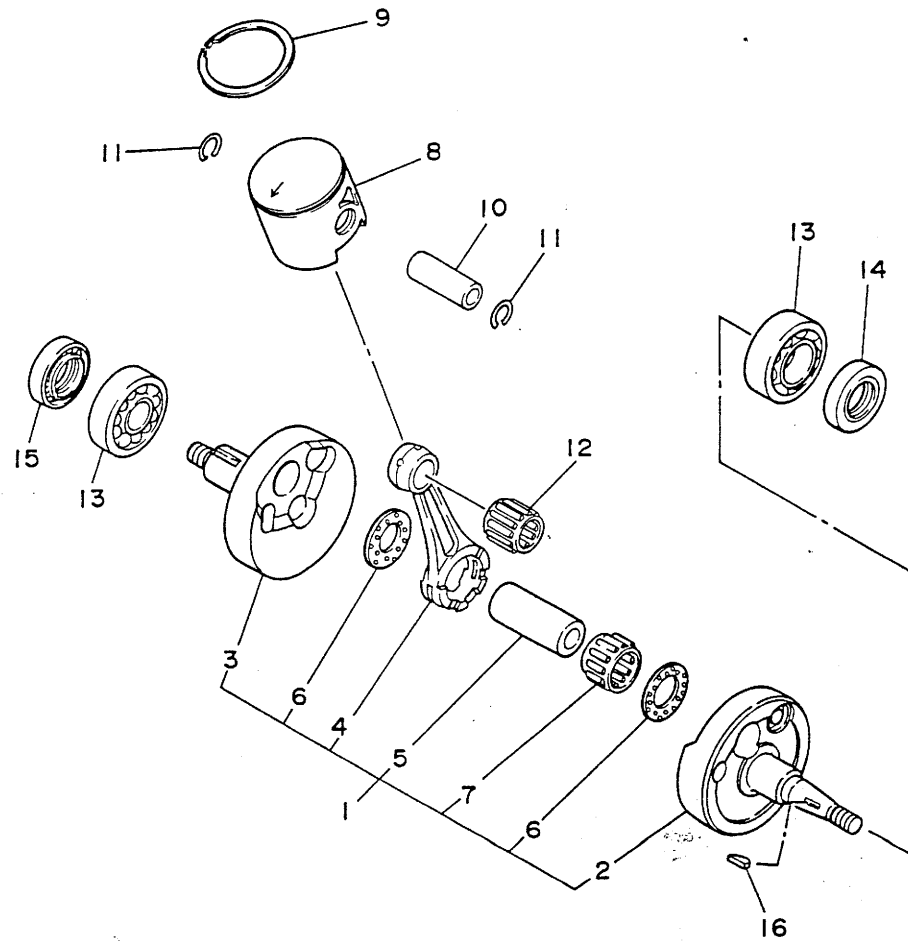

REF. NO.	PART NO.	DESCRIPTION	Q'TY	REMARKS
1	3XJ-11400-00	CRANKSHAFT ASSY	1	
2	3SR-11412-00	.CRANK 1	1	
3	3XJ-11422-00	.CRANK 2	1	
4	2HG-11651-00	.ROD, connecting	1	
5	3JD-11681-00	.PIN, crank 1	1	
6	90209-22257	.WASHER	2	
7	93310-522M4	.BEARING, cylindrical	1	
8	3XJ-11631-00-A0	PISTON (STD)	1	UR RED 7
	3XJ-11631-00-B0	PISTON (STD)	1	UR ORANGE 28
	3XJ-11631-00-C0	PISTON (STD)	1	UR GREEN 15
	3XJ-11631-00-D0	PISTON (STD)	1	UR PURPLE 41
9	5X4-11611-01	RING, piston	1	
10	137-11633-00	PIN, piston	1	
11	93450-17129	CIRCLIP	2	
12	93310-216L2	BEARING, cylindrical	1	
13	93306-37204	BEARING	2	
14	93102-22363	OIL SEAL	1	
15	93103-32171	OIL SEAL	1	
16	90280-03045	KEY, woodruff	1	

FWD

FIG. 4 WATER PUMP

REF. NO.	PART NO.	DESCRIPTION	Q'TY	REMARKS
1	3JD-12459-00	GEAR, impeller shaft	1	
2	1LX-12450-00	IMPELLER SHAFT ASSY	1	
3	99080-07600	CIRCLIP	1	
4	90201-08512	WASHER, plate	1	
5	93603-22028	PIN, dowel	1	
6	90201-08784	WASHER, plate	1	
7	90381-08002	BUSH, solid	1	
8	93103-10147	OIL SEAL	1	
9	93300-60814	BEARING	1	
10	2VN-12422-01	COVER, housing	1	
11	1LX-12428-01	GASKET, housing cover 2	1	
12	93604-10011	PIN, dowel	2	
13	95023-06025	BOLT	2	
14	90430-06166	GASKET	1	
15	95021-06060	BOLT, flange	1	

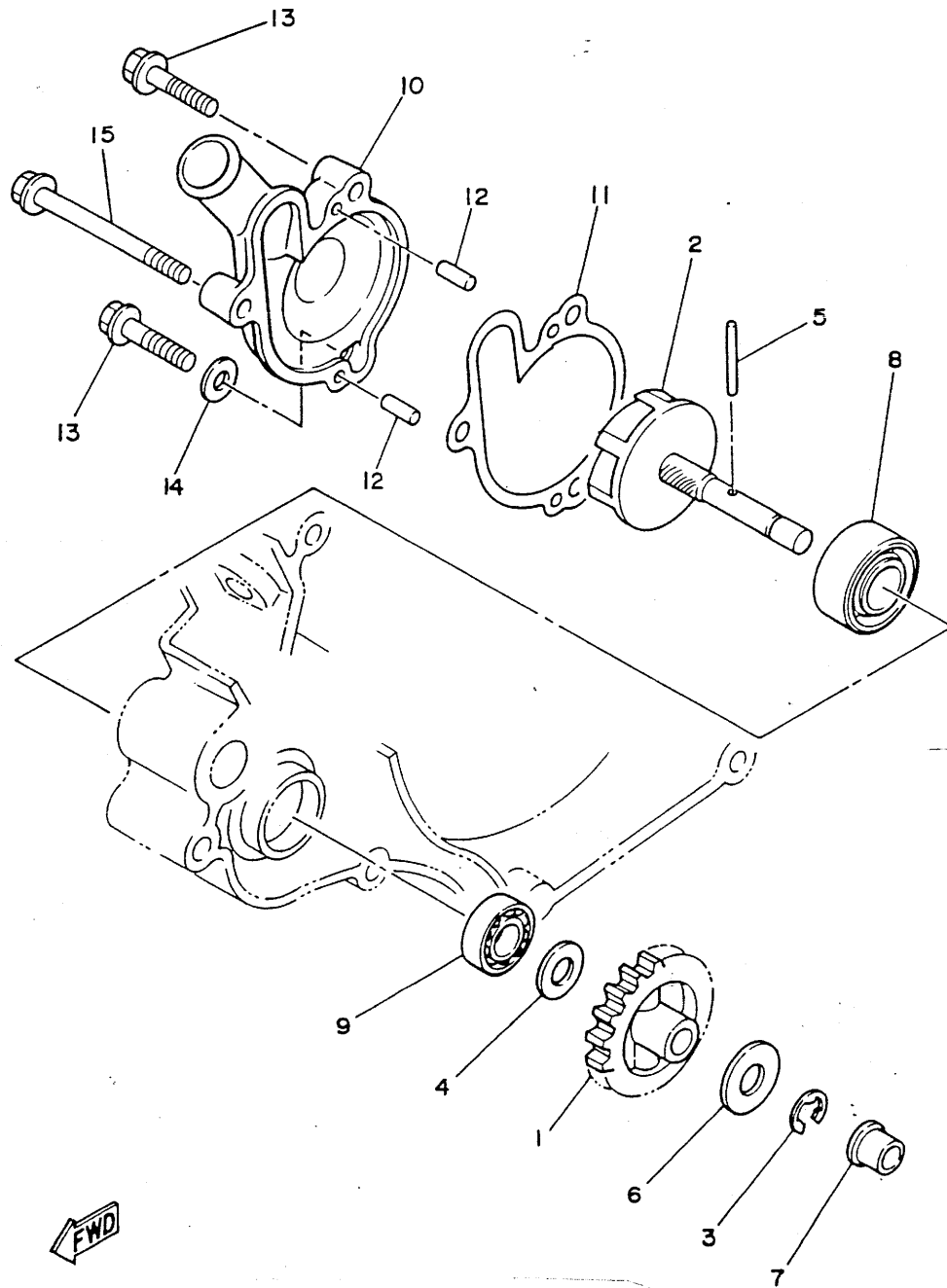
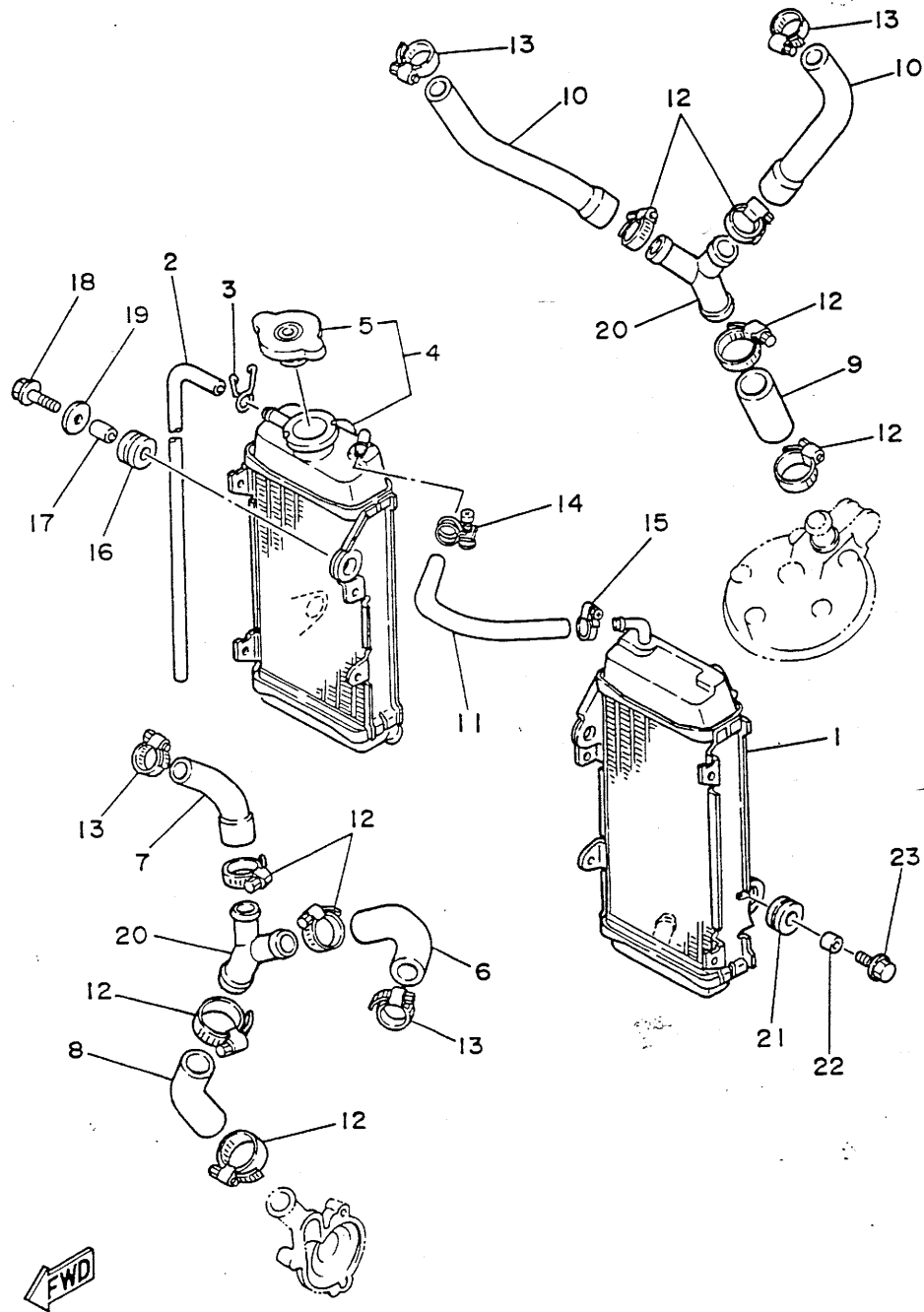
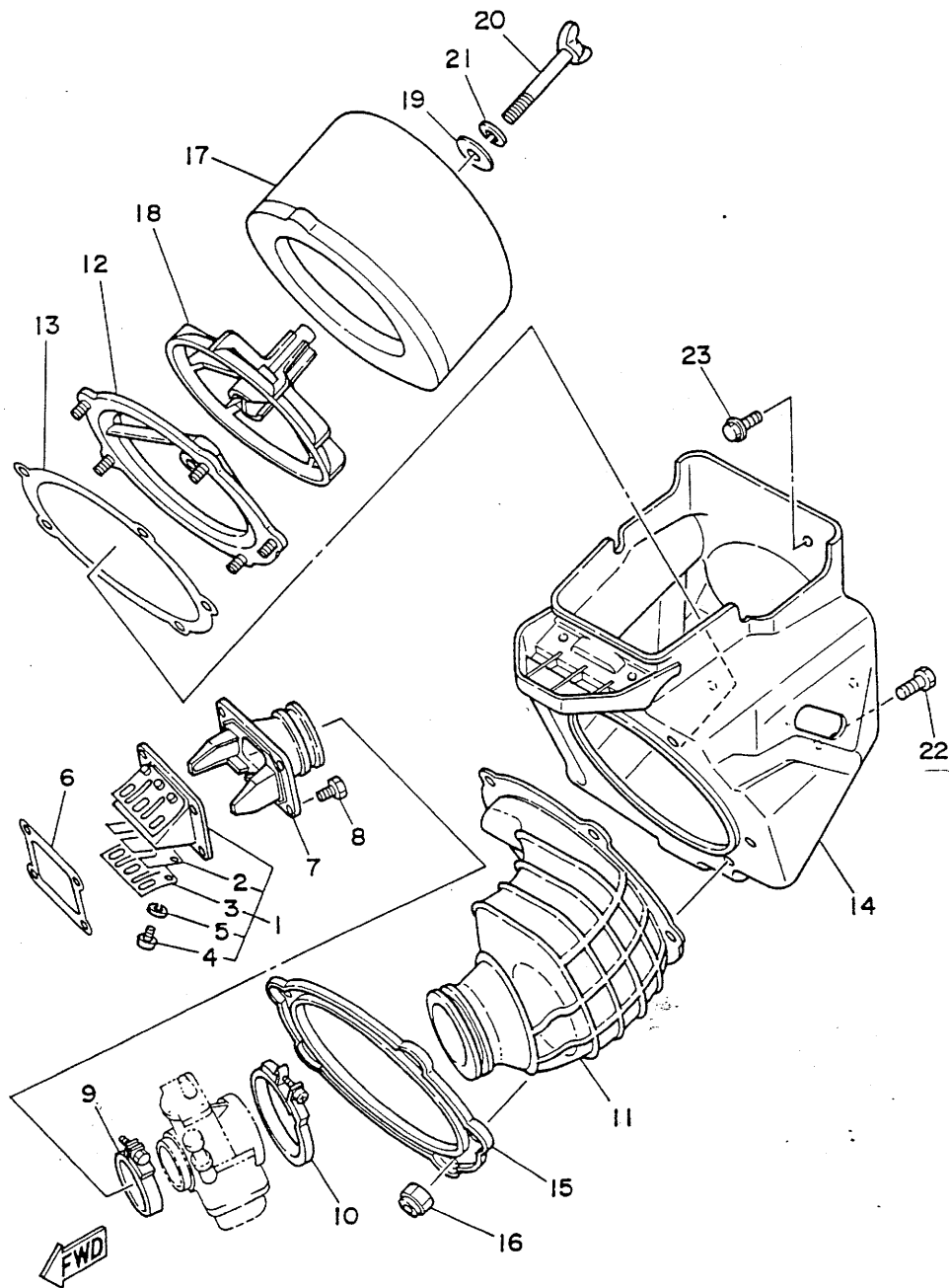

FIG. 5 RADIATOR. HOSE



REF. NO.	PART NO.	DESCRIPTION	Q'TY	REMARKS
1	3JD-1240A-00	RADIATOR ASSY 2	1	
2	90446-09013	HOSE	1	
3	90467-09006	CLIP	1	
4	1LX-1240A-00	RADIATOR ASSY 2	1	
5	22W-12462-00	.CAP, radiator	1	
6	3JD-12481-01	PIPE 1	1	
7	3JD-12482-00	PIPE 2	1	
8	3JD-12483-00	PIPE 3	1	
9	3JD-12485-00	PIPE 5	1	
10	3JD-12476-00	PIPE 6	2	
11	1LU-1248A-01	PIPE 8	1	
12	90450-28014	HOSE CLAMP ASSY	8	
13	90450-22017	HOSE CLAMP ASSY	4	
14	90450-15041	HOSE CLAMP ASSY	1	
15	90450-17036	HOSE CLAMP ASSY	1	
16	90480-15064	GROMMET	2	
17	90387-074W0	COLLAR	2	
18	95023-06030	BOLT	2	
19	90201-06570	WASHER, plate	2	
20	24X-12469-00	JOINT 1	2	
21	90480-18276	GROMMET	2	
22	90387-064W1	COLLAR	2	
23	95023-06020	BOLT	2	

FIG. 6 INTAKE



REF. NO.	PART NO.	DESCRIPTION	Q'TY	REMARKS
1	2VN-13610-00	REED VALVE ASSY	1	
2	1RX-13613-00	.REED, valve	2	
3	2VN-13616-00	.STOPPER, reed valve	2	
4	98580-03008	.SCREW, pan head	6	
5	92990-03100	.WASHER, spring	6	
6	2K7-13621-10	GASKET, valve seat	1	
7	3SR-13565-00	JOINT, carburetor	1	
8	95023-06020	BOLT	4	
9	90460-51109	CLAMP, hose	1	
10	90460-68230	CLAMP, hose	1	
11	3XJ-14453-00	JOINT, air cleaner 1	1	
12	3JD-14459-00	HOLDER, guide	1	
13	3JD-14462-00	SEAL	1	
14	3XJ-W1441-00	AIR CLEANER CASE COMP.	1	
15	3JD-14477-00	PLATE	1	
16	95601-05100	NUT, u	5	
17	3JD-14451-00	ELEMENT, air cleaner	1	
18	3JD-14458-00	GUIDE	1	
19	90209-06096	WASHER	1	
20	90122-06030	BOLT, wing	1	
21	92990-06100	WASHER, spring	1	
22	95023-06010	BOLT	1	
23	90119-06185	BOLT, with washer	2	

FIG. 7 CARBURETOR

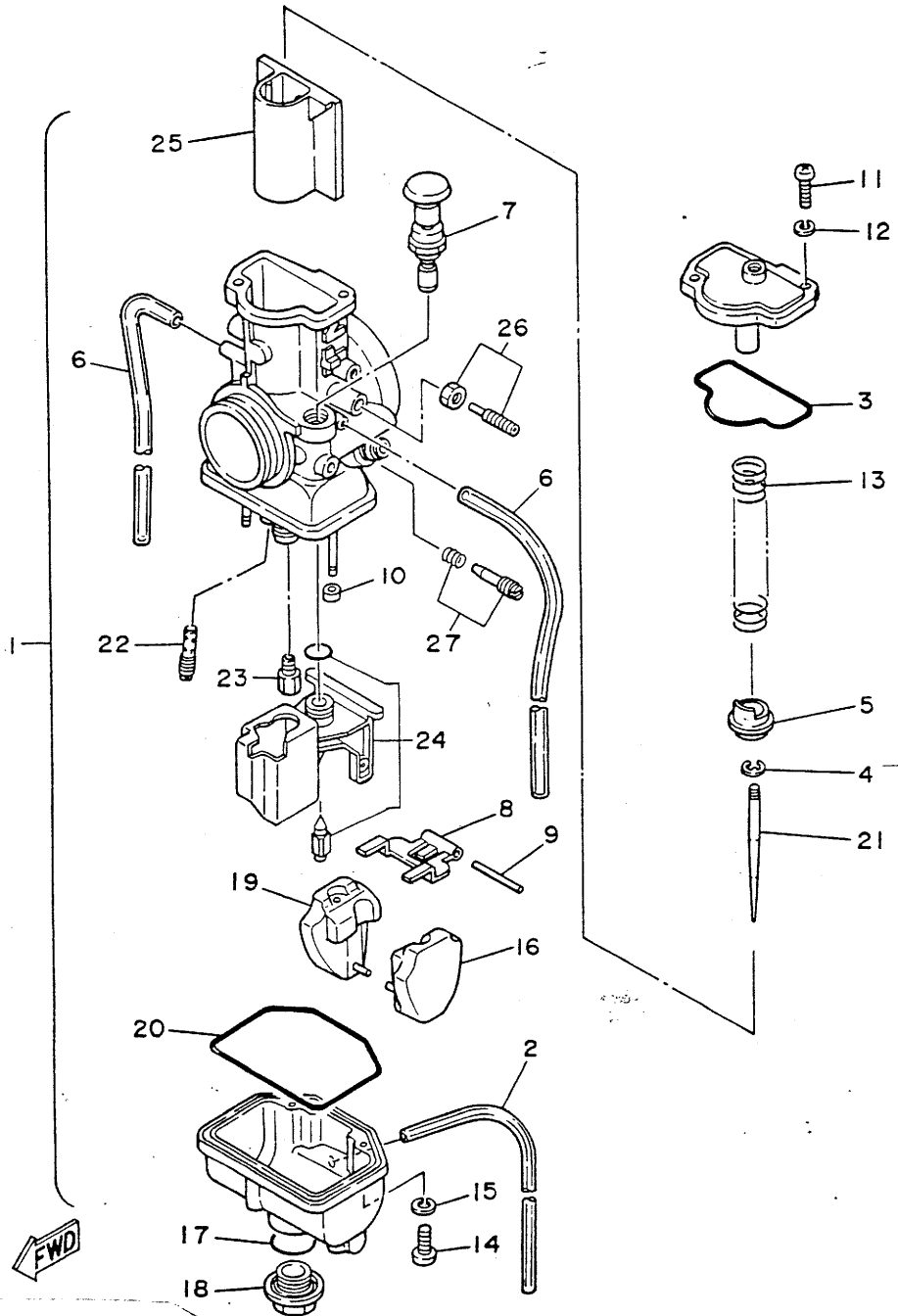

REF. NO.	PART NO.	DESCRIPTION	Q'TY	REMARKS
1	3XJ-14101-00	CARBURETOR ASSY 1	1	
2	278-14197-00	.PIPE	1	
3	3JD-14147-00	.O-RING	1	
4	256-14919-00	.CLIP	1	
5	3JD-14194-00	.RING	1	
6	2HH-14197-00	.PIPE	2	
7	3JE-14171-00	.PLUNGER, starter	1	
8	363-14187-00	.ARM, float	1	
9	353-14186-00	.PIN, float	1	
10	214-14118-00	.CAP	2	
11	98511-04012	.SCREW, pan head	2	
12	92902-04100	.WASHER, spring	2	
13	3JD-14131-00	.SPRING, throttle valve	1	
14	98580-03008	.SCREW, pan head	1	
15	92990-03100	.WASHER, spring	1	
16	3JD-14185-00	.FLOAT	1	
17	3JE-14561-00	.O-RING	1	
18	3JD-14115-00	.PLUG, screw	1	
19	3JE-14185-00	.FLOAT	1	
20	3JE-14147-00	.O-RING	1	
21	3JD-14116-A2	.NEEDLE (J8-6EN15-53)	1	AP
	3JD-14116-A3	.NEEDLE (J8-6EN15-54)	1	AP
	3JD-14116-A1	.NEEDLE (J8-6EN15-55)	1	AP STD
	3JD-14116-A4	.NEEDLE (J8-6EN15-56)	1	AP
	3JD-14116-A5	.NEEDLE (J8-6EN15-57)	1	AP
22	193-14142-17	.JET, pilot (#17.5)	1	AP

FIG. 7 CARBURETOR

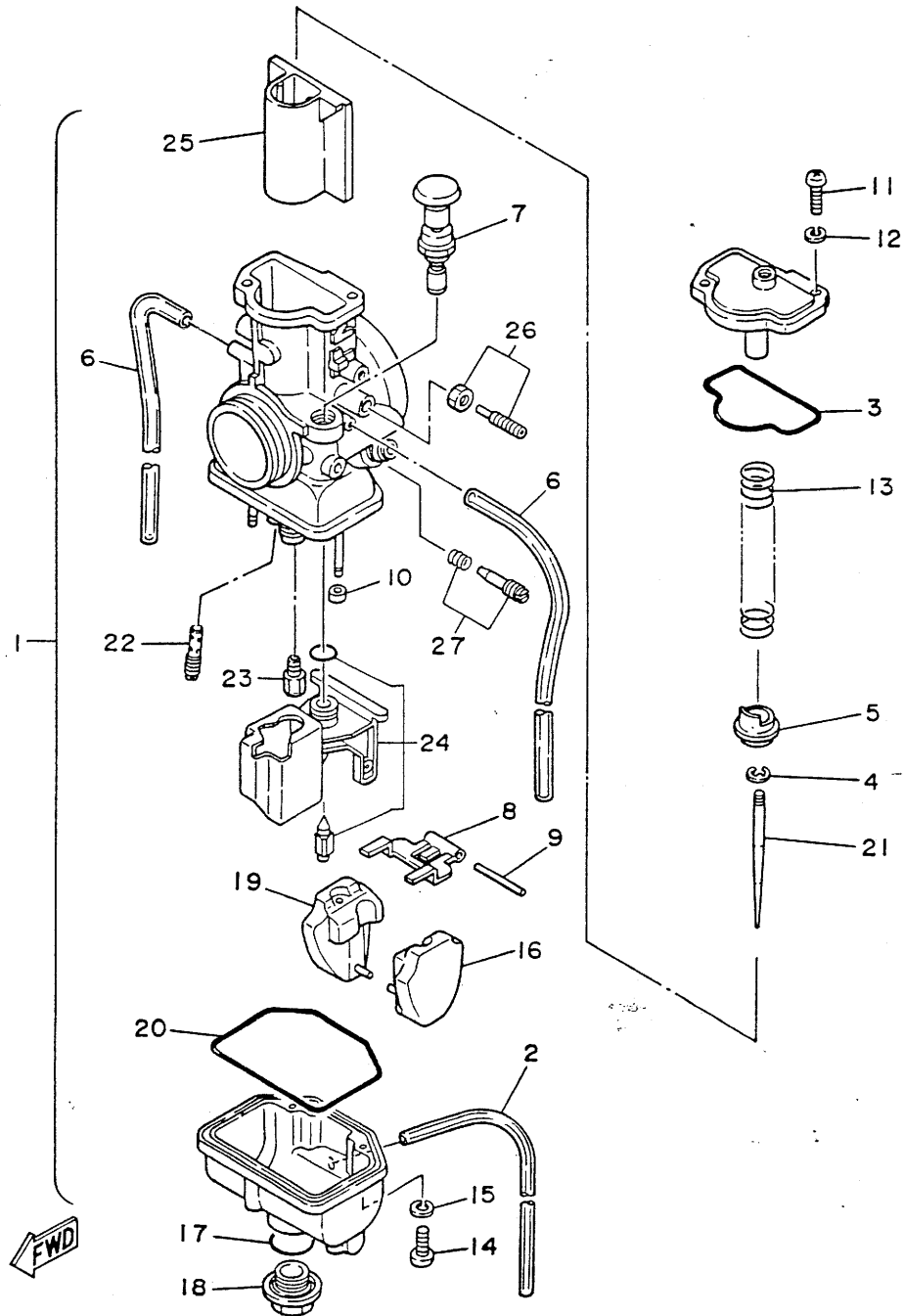

REF. NO.	PART NO.	DESCRIPTION	Q'TY	REMARKS
22	193-14142-20	.JET, pilot (#20)	1	AP STD
	193-14142-25-A0	.JET, pilot (#25)	1	AP
	193-14142-30-A0	.JET, pilot (#30)	1	AP
	193-14142-35	.JET, pilot (#35)	1	AP
23	137-14143-56-A0	.JET, main (#280)	1	AP
	137-14143-58-A1	.JET, main (#290)	1	AP
	137-14143-60-A0	.JET, main (#300)	1	AP
	137-14143-62-A1	.JET, main (#310)	1	AP
	137-14143-64	.JET, main (#320)	1	AP
	137-14143-66	.JET, main (#330)	1	AP STD
	137-14143-68	.JET, main (#340)	1	AP
	137-14143-70	.JET, main (#350)	1	AP
24	3JD-14107-35	.NEEDLE VALVE SET	1	
25	3JD-14112-50	.VALVE, throttle (C.A 5.0)	1	AP
	3JD-14112-55	.VALVE, throttle (C.A 5.5)	1	AP
	3JD-14112-60	.VALVE, throttle (C.A 6.0)	1	AP STD
26	3JD-14103-00	.THROTTLE SCREW SET	1	
27	3JD-14104-00	.AIR SCREW SET	1	

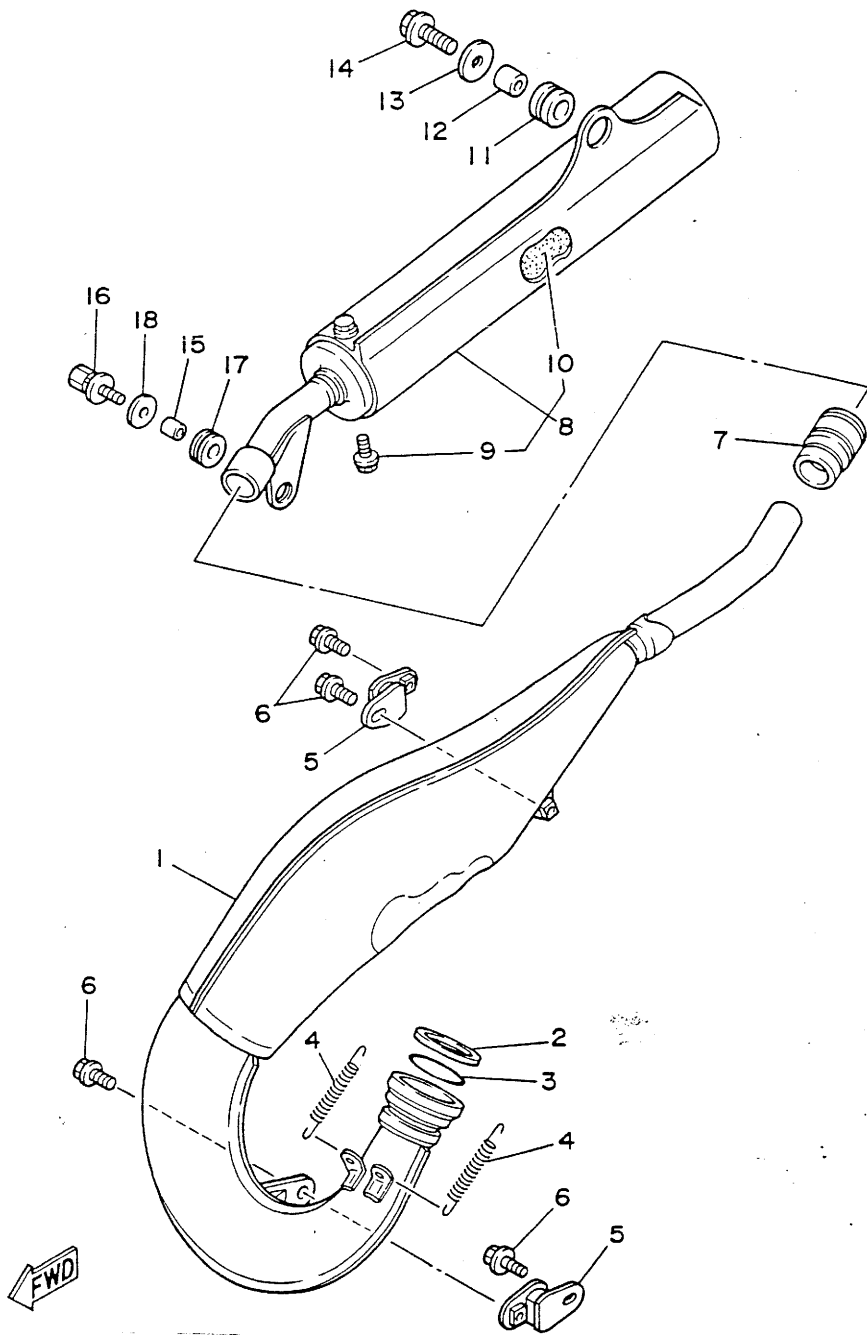
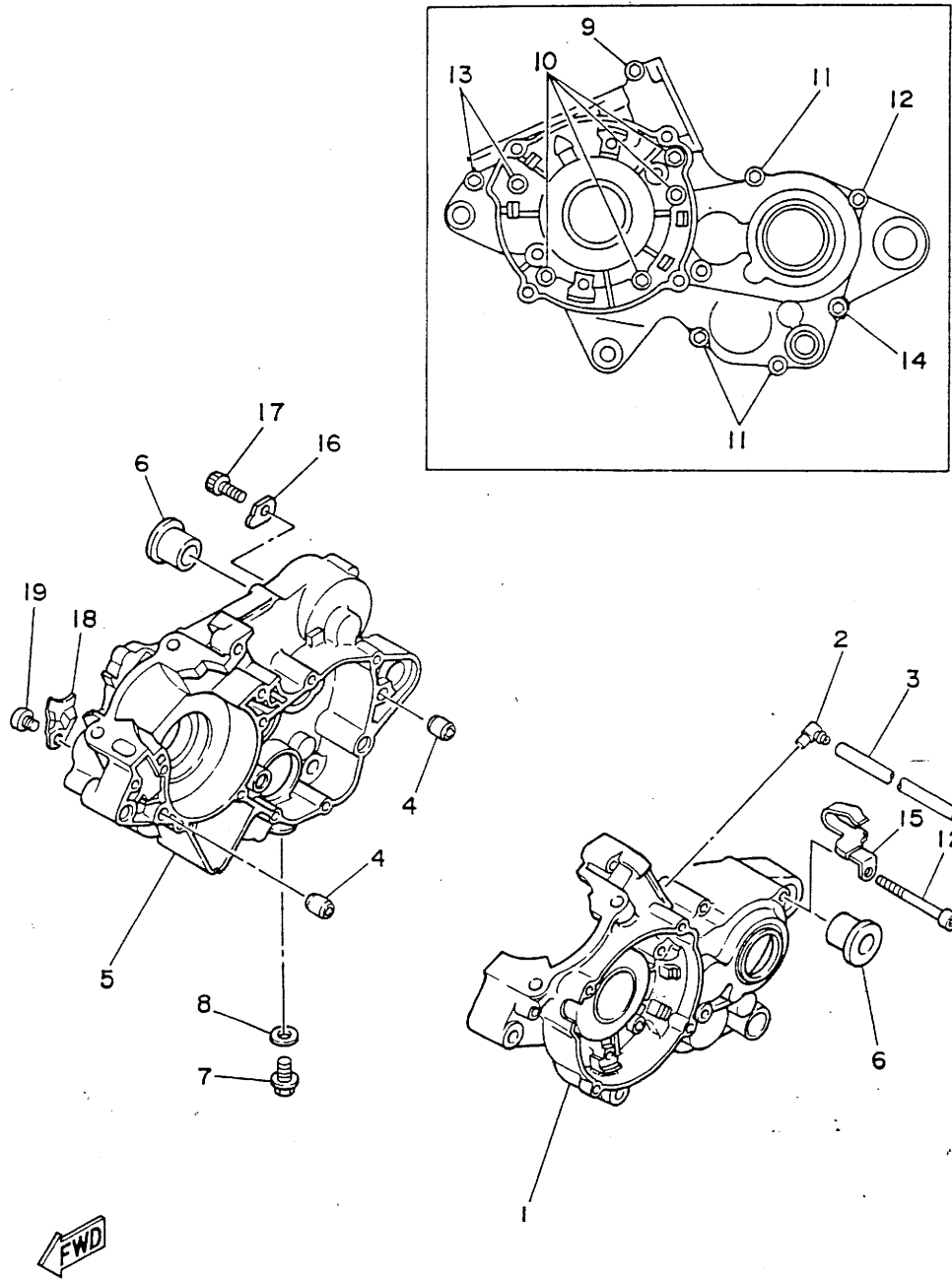

FIG. 8 EXHAUST

REF. NO.	PART NO.	DESCRIPTION	Q'TY	REMARKS
1	3XJ-14610-00	EXHAUST PIPE ASSY 1	1	
2	3R3-14613-00	GASKET, exhaust pipe	1	
3	93210-45742	O-RING	1	
4	90507-20030	SPRING, tension	2	
5	565-14771-00	STAY, muffler 1	2	
6	95023-06010	BOLT	4	
7	3M7-14615-00	JOINT, exhaust 1	1	
8	3XJ-14753-00	SILENCER, exhaust SILENCER, exhaust	1 1	
9	95023-06008	.BOLT	2	
10	3XJ-1469A-00	.FIBER	1	
			1	UR
11	39X-14747-00	DAMPER, muffler	1	
12	90387-100Y1	COLLAR	1	
13	90201-08612	WASHER, plate	1	
14	95021-08030	BOLT, flange	1	
15	90387-060A7	COLLAR	1	
16	90109-064F4	BOLT	1	
17	90480-16233	GROMMET	1	
18	90201-06407	WASHER, plate	1	

FIG. 9 CRANKCASE



REF. NO.	PART NO.	DESCRIPTION	Q'TY	REMARKS
1	1LX-15111-12	CRANKCASE 1	1	
2	353-13115-01	CONNECTOR, suction pipe	1	
3	90445-08376	HOSE	1	
4	99510-12016	PIN, dowel	2	
5	1LX-15121-12	CRANKCASE 2	1	
6	90387-16781	COLLAR	2	
7	90340-12059	PLUG, straight screw	1	
8	90430-12207	GASKET	1	
9	91316-06035	BOLT	1	
10	91316-06045	BOLT	4	
11	91316-06055	BOLT	3	
12	91316-06070	BOLT	1	
13	91316-06060	BOLT	2	
14	91316-06065	BOLT	1	
15	90465-08336	CLAMP	1	
16	90209-06290	WASHER	1	
17	91316-05012	BOLT	1	
18	3R3-15128-01	HOLDER	1	
19	92501-08010	SCREW, pan head	1	

FIG. 10 CRANKCASE COVER 1

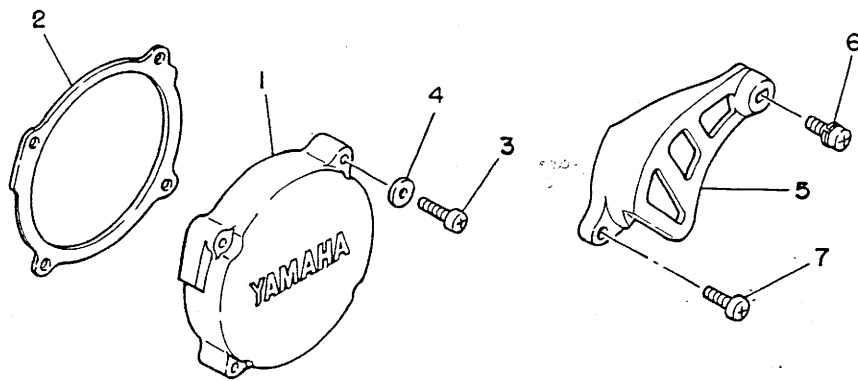
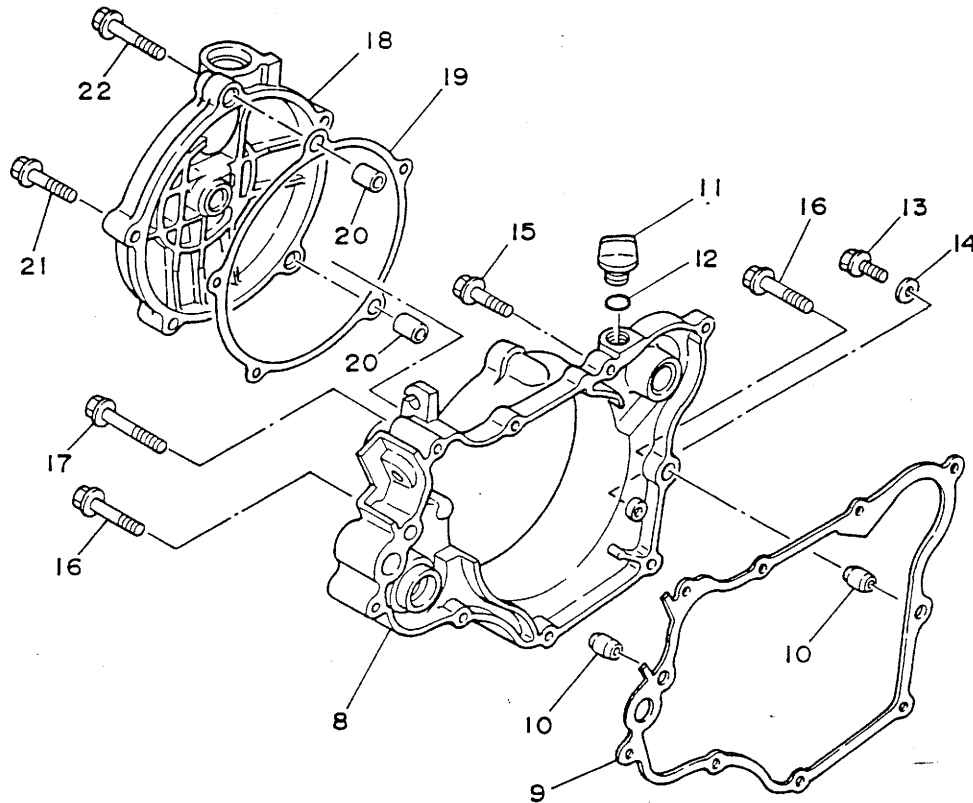

FWD

REF. NO.	PART NO.	DESCRIPTION	Q'TY	REMARKS
1	2VN-15411-00	COVER, crankcase 1	1	
2	1LX-15451-11	GASKET, crankcase cover 1	1	
3	98501-06035	SCREW, pan head	4	
4	92901-06600	WASHER, plate	4	
5	3SR-15421-00	COVER, crankcase 2	1	
6	90159-06146	SCREW, with washer	1	
7	98501-06016	SCREW, pan head	1	
8	3JD-15431-00	COVER, crankcase 3	1	
9	1LX-15462-10	GASKET, crankcase cover 3	1	
10	99530-10014	PIN, dowel	2	
11	1G8-15362-00	PLUG, oil level	1	
12	93210-14104	O-RING	1	
13	95023-06008	BOLT	1	
14	90430-06016	GASKET	1	
15	95023-06025	BOLT	6	
16	95023-06035	BOLT	2	
17	95023-06040	BOLT	1	
18	3XJ-15415-00	COVER, generator	1	
19	3JD-15463-10	GASKET, carburetor cover 2	1	
20	99530-10014	PIN, dowel	2	
21	95023-06030	BOLT	3	
22	95023-06040	BOLT	2	

FIG. 11 STARTER

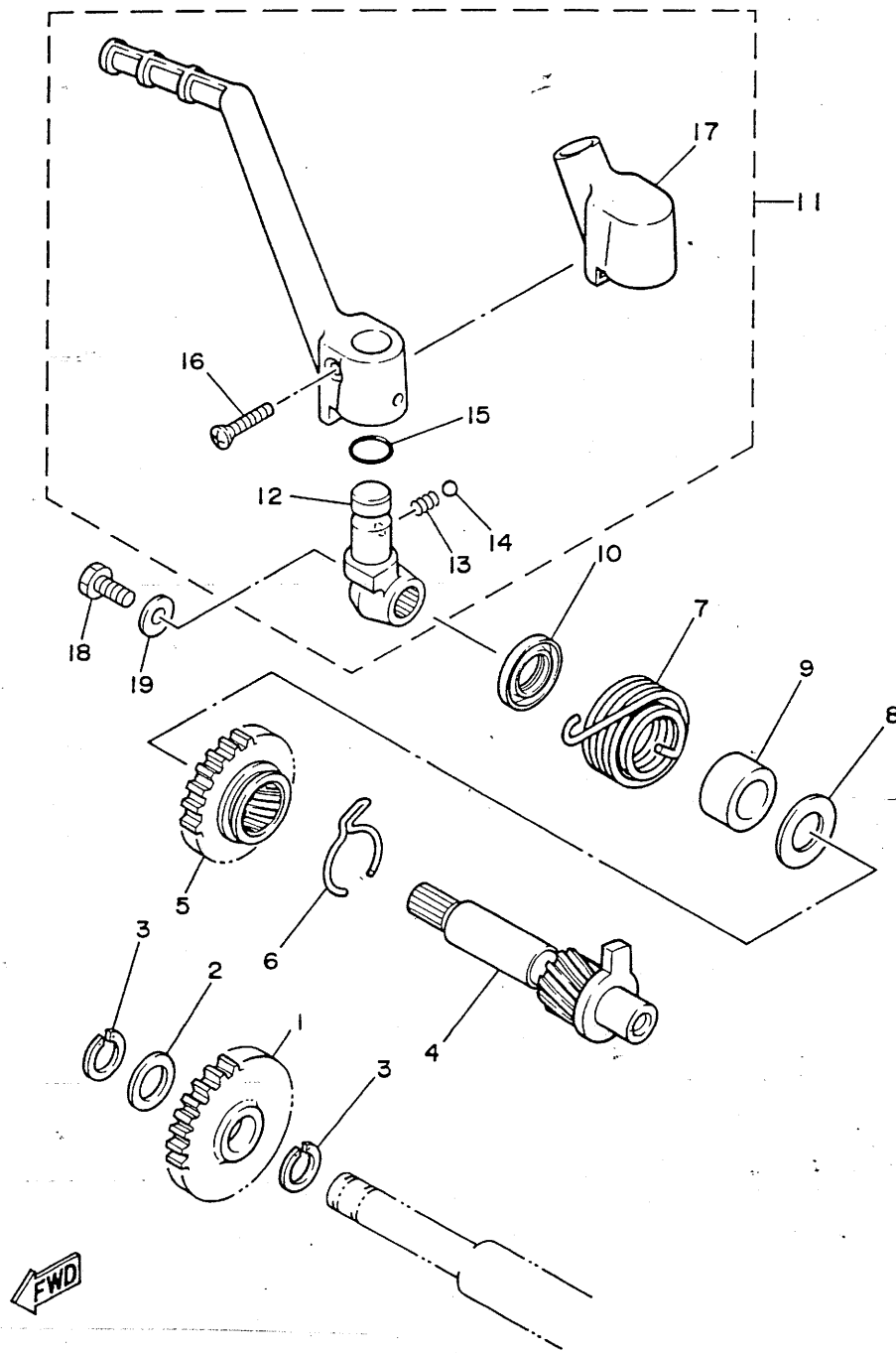

REF. NO.	PART NO.	DESCRIPTION	Q'TY	REMARKS
1	1LX-15651-00	GEAR, kick idle	1	
2	137-17417-00-05	SHIM 1 (0.5T)	1	
3	93440-15012	CIRCLIP	2	
4	1LX-15660-00	KICK AXLE ASSY	1	
5	1LX-15641-00	GEAR, kick	1	
6	90468-26048	CLIP	1	
7	90508-26700	SPRING, torsion	1	
8	90201-17164	WASHER, plate	1	
9	90560-17279	SPACER	1	
10	93102-17263	OIL SEAL	1	
11	1LX-15620-01	KICK CRANK ASSY	1	
12	1LX-15621-01	.BOSS, kick crank	1	
13	90501-12081	.SPRING, compression	1	
14	93507-32031	.BALL	1	
15	93210-15151	.O-RING	1	
16	90152-06010	.SCREW, countersunk	1	
17	1LX-15618-00	.COVER, kick lever	1	
18	97021-06012	BOLT	1	
19	90201-065F3	WASHER, plate	1	

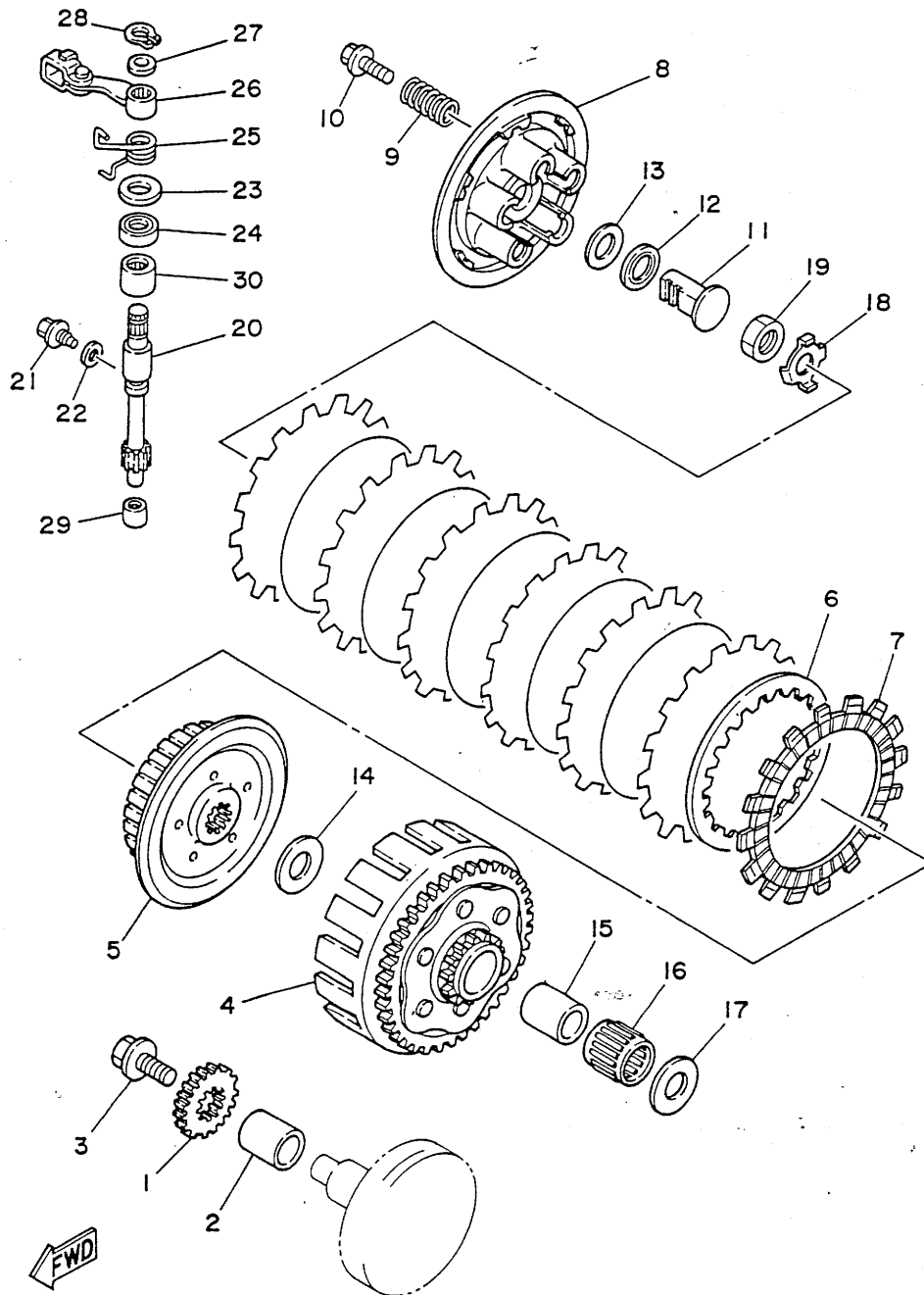
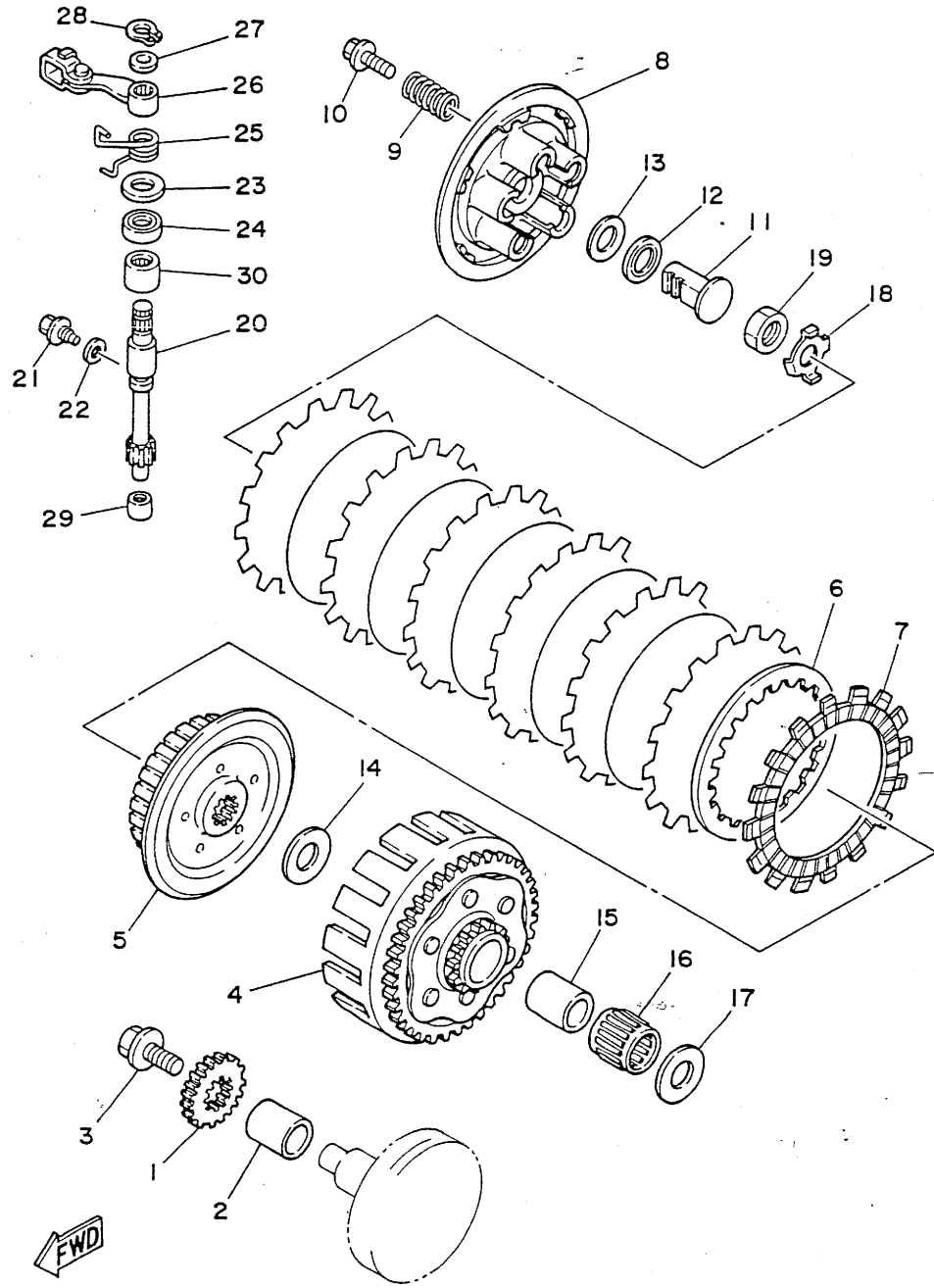

FIG. 12 CLUTCH

REF. NO.	PART NO.	DESCRIPTION	Q'TY	REMARKS
1	3XJ-16111-00	GEAR, primary drive	1	
2	90387-202T9	COLLAR	1	
3	90105-10445	BOLT, washer based	1	
4	3XJ-16150-00	PRIMARY DRIVEN GEAR COMP.	1	
5	3XJ-16371-00	BOSS, clutch	1	
6	3XJ-16324-00	PLATE, clutch 1	6	
7	3XJ-16321-00	PLATE, friction	7	
8	3XJ-16351-00	PLATE, pressure 1	1	
9	90501-23598	SPRING, compression	5	
10	90159-06016	SCREW, with washer	5	
11	3XJ-16356-00	ROD, push 1	1	
12	93340-21505	BEARING, thrust	1	
13	90201-150H2	WASHER, plate	1	
14	90201-204K8	WASHER, plate	1	
15	3XJ-16181-00	SPACER 1	1	
16	93310-225N0	BEARING, cylindrical	1	
17	3XJ-16164-00	PLATE, thrust 2	1	
18	90215-16320	WASHER, lock	1	
19	90170-16326	NUT	1	
20	3JD-16382-00	AXLE, push lever	1	
21	90109-06418	BOLT	1	
22	90430-06014	GASKET	1	
23	90201-12474	WASHER, plate	1	
24	93102-15212	OIL SEAL	1	
25	90508-14767	SPRING, torsion	1	
26	3JD-16340-00	PUSH LEVER ASSY	1	
27	90201-10119	WASHER, plate	1	
28	99009-10400	CIRCLIP	1	

FIG. 12 CLUTCH



REF. NO.	PART NO.	DESCRIPTION	Q'TY	REMARKS
----------	----------	-------------	------	---------

29	93315-10838	BEARING, cylindrical	1	
----	-------------	----------------------	---	--

30	93315-31502	BEARING, cylindrical	1	
----	-------------	----------------------	---	--

FIG. 13 TRANSMISSION

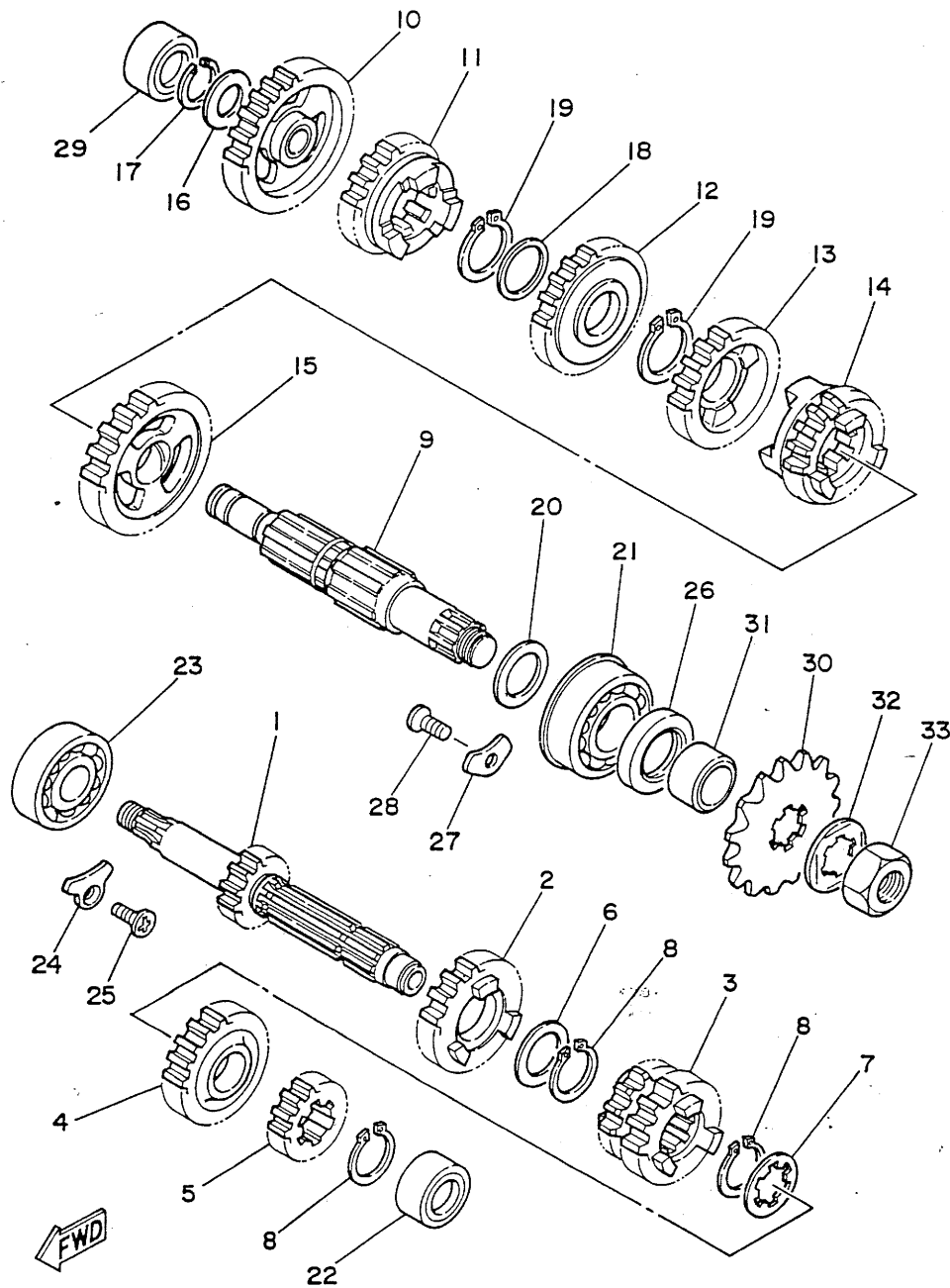

REF. NO.	PART NO.	DESCRIPTION	Q'TY	REMARKS
1	3XJ-17411-00	AXLE, main	1	
2	3JD-17151-00	GEAR, 5th pinion (20T)	1	
3	3SR-17131-00	GEAR, 3rd pinion	1	
4	3JD-17161-00	GEAR, 6th pinion (21T)	1	
5	3SR-17121-00	GEAR, 2nd pinion	1	
6	90201-22555	WASHER, plate	1	
7	90209-18135	WASHER	1	
8	93410-22039	CIRCLIP	3	
9	3XJ-17421-00	AXLE, drive	1	
10	1LX-17211-00	GEAR, 1st wheel (30T)	1	
11	3JD-17251-00	GEAR, 5th wheel (23T)	1	
12	3SR-17231-00	GEAR, 3rd wheel	1	
13	1LX-17241-00	GEAR, 4th wheel (22T)	1	
14	3XJ-17261-00	GEAR, 6th wheel	1	
15	3XJ-17221-00	GEAR, 2nd wheel	1	
16	90201-15701	WASHER, plate (1.0T)	1	
17	93440-15012	CIRCLIP	1	
18	90209-18208	WASHER	1	
19	93410-22039	CIRCLIP	2	
20	90201-206X8	WASHER, plate	1	
21	93306-30411	BEARING (B6304)	1	
22	93311-41530	BEARING, cylindrical	1	
23	93306-20431	BEARING (B6204Z)	1	
24	1LX-15383-00	PLATE, bearing cover	1	
25	98701-06012	SCREW, flat head	1	
26	93102-26042	OIL SEAL	1	
27	3XJ-15383-00	PLATE, bearing cover	2	
28	98701-06012	SCREW, flat head	2	

FIG. 13 TRANSMISSION

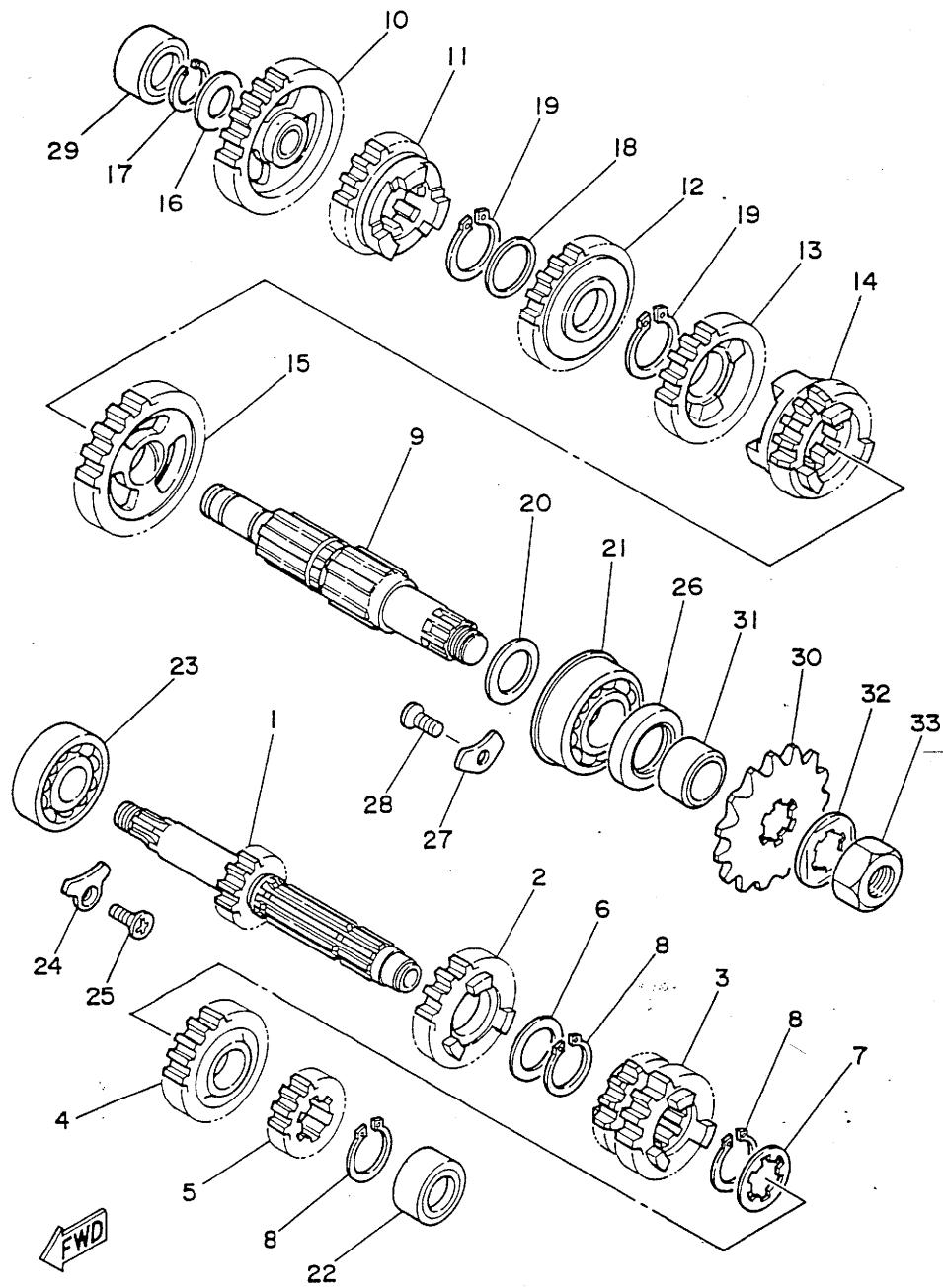

REF. NO.	PART NO.	DESCRIPTION	Q'TY	REMARKS
29	93311-31567	BEARING, cylindrical	1	
30	9383A-13031	SPROCKET,drive 13T (2HG1746130)	1	STD
	9383A-12017	SPROCKET,drive 12T (2HG1746120)	1	AP
	9383A-14054	SPROCKET,drive 14T (2HG1746140)	1	AP
31	90387-202A0	COLLAR	1	
32	90215-20261	WASHER, lock	1	
33	90179-16226	NUT	1	

FIG. 14 SHIFT CAM. FORK

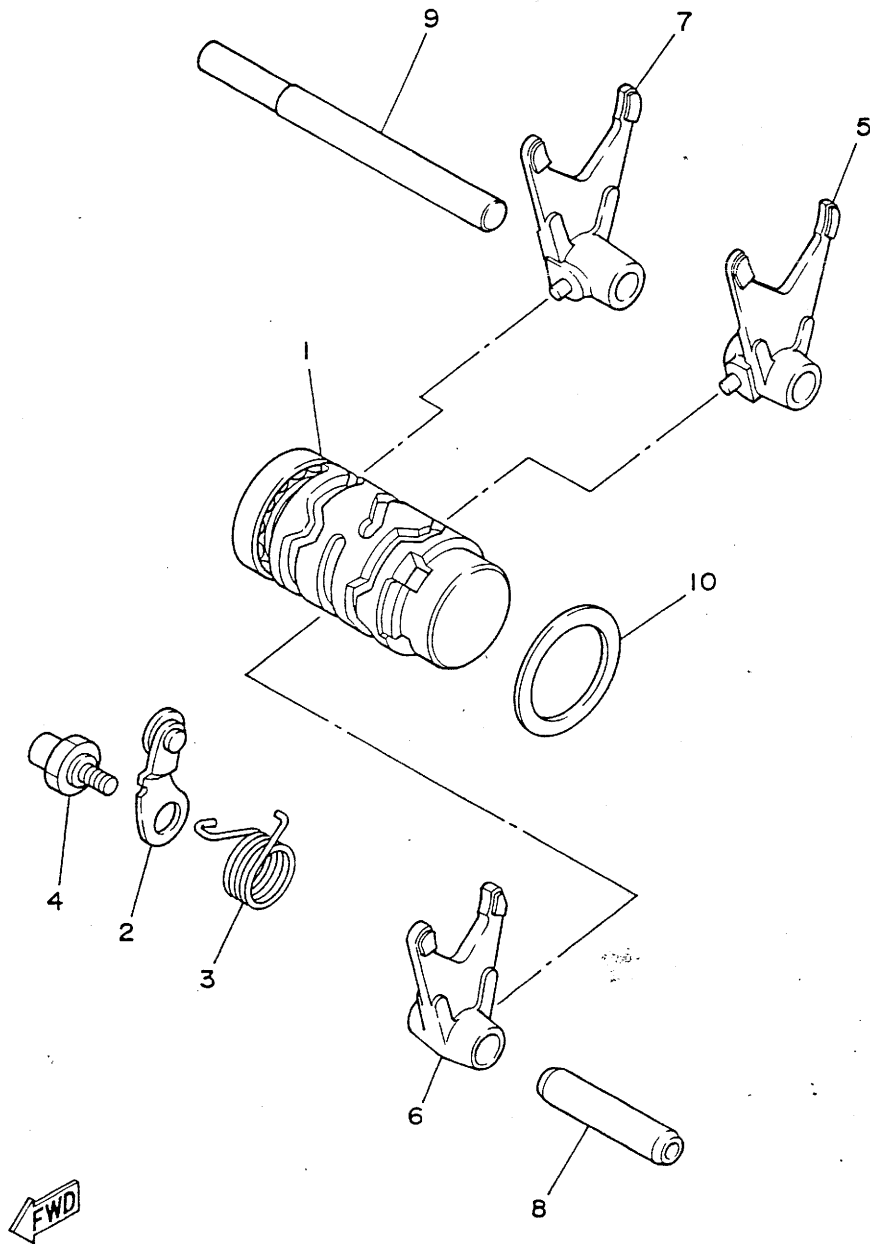

REF. NO.	PART NO.	DESCRIPTION	Q'TY	REMARKS
1	3XJ-18540-00	SHIFT CAM ASSY	1	
2	3XJ-18140-00	STOPPER LEVER ASSY	1	
3	90508-240A7	SPRING, torsion	1	
4	3XK-18177-00	BOLT, stopper	1	
5	3JD-18511-01	FORK, shift 1	1	
6	2VN-18512-01	FORK, shift 2	1	
7	1LX-18513-01	FORK, shift 3	1	
8	1LX-18531-00	BAR, shift fork guide 1	1	
9	1LX-18535-00	BAR, shift fork guide 2	1	
10	90201-34683	WASHER, plate	1	

FIG. 15 SHIFT SHAFT

REF. NO.	PART NO.	DESCRIPTION	Q'TY	REMARKS
1	3XJ-18101-00	SHIFT SHAFT ASSY	1	
2	3XJ-18122-00	LEVER, shift 2'	1	
3	90508-290A8	SPRING, torsion	1	
4	90560-12280	SPACER	1	
5	1LX-18110-01	SHIFT PEDAL ASSY	1	
6	98021-06025	BOLT	1	
7	93109-12012	OIL SEAL	1	
8	3XJ-18173-00	PIN, shift	1	
9	3XJ-18178-00	ROLLER, shift lever	1	
10	3XJ-18182-00	PAWL, shifter	2	
11	90501-052G5	SPRING, compression	2	
12	3XJ-18184-00	PIN, pawl	2	
13	3XJ-18172-00	GUIDE, shift	1	
14	90101-06664	BOLT	2	
15	3XJ-18185-00	SEGMENT	1	

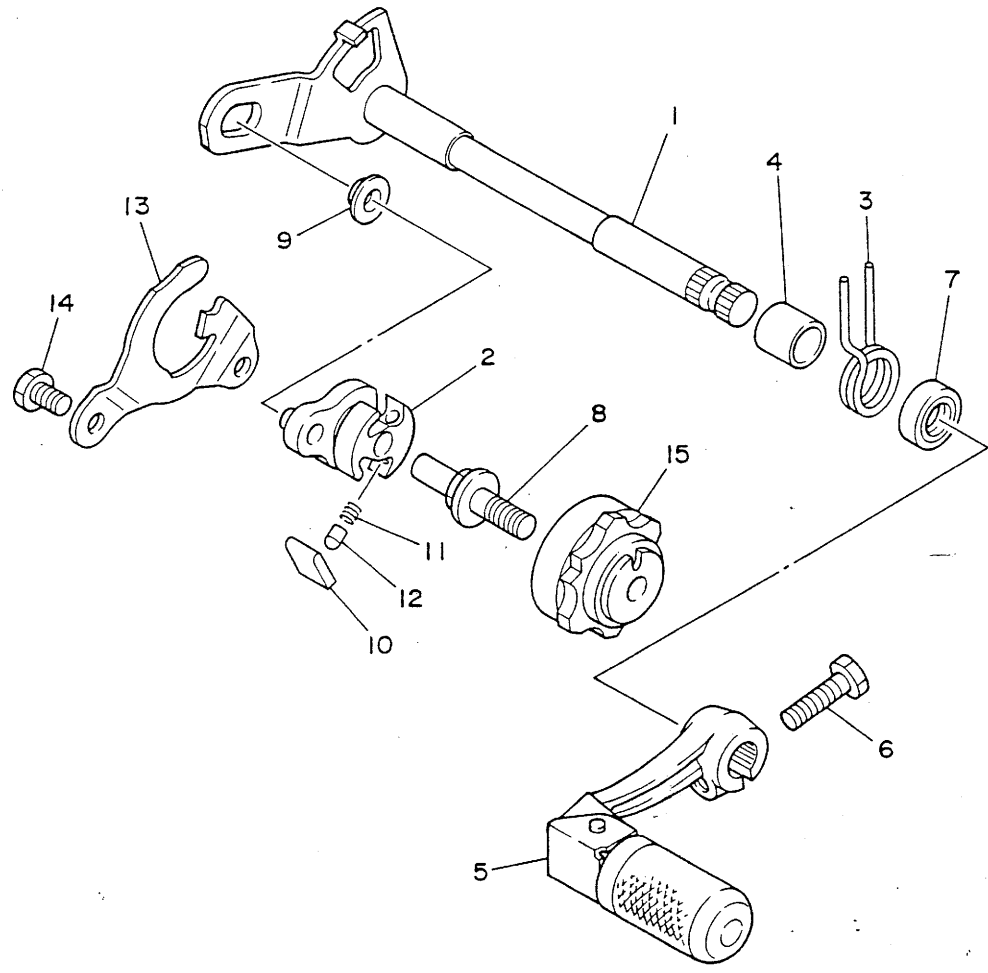

FWD

FIG. 16 FRAME

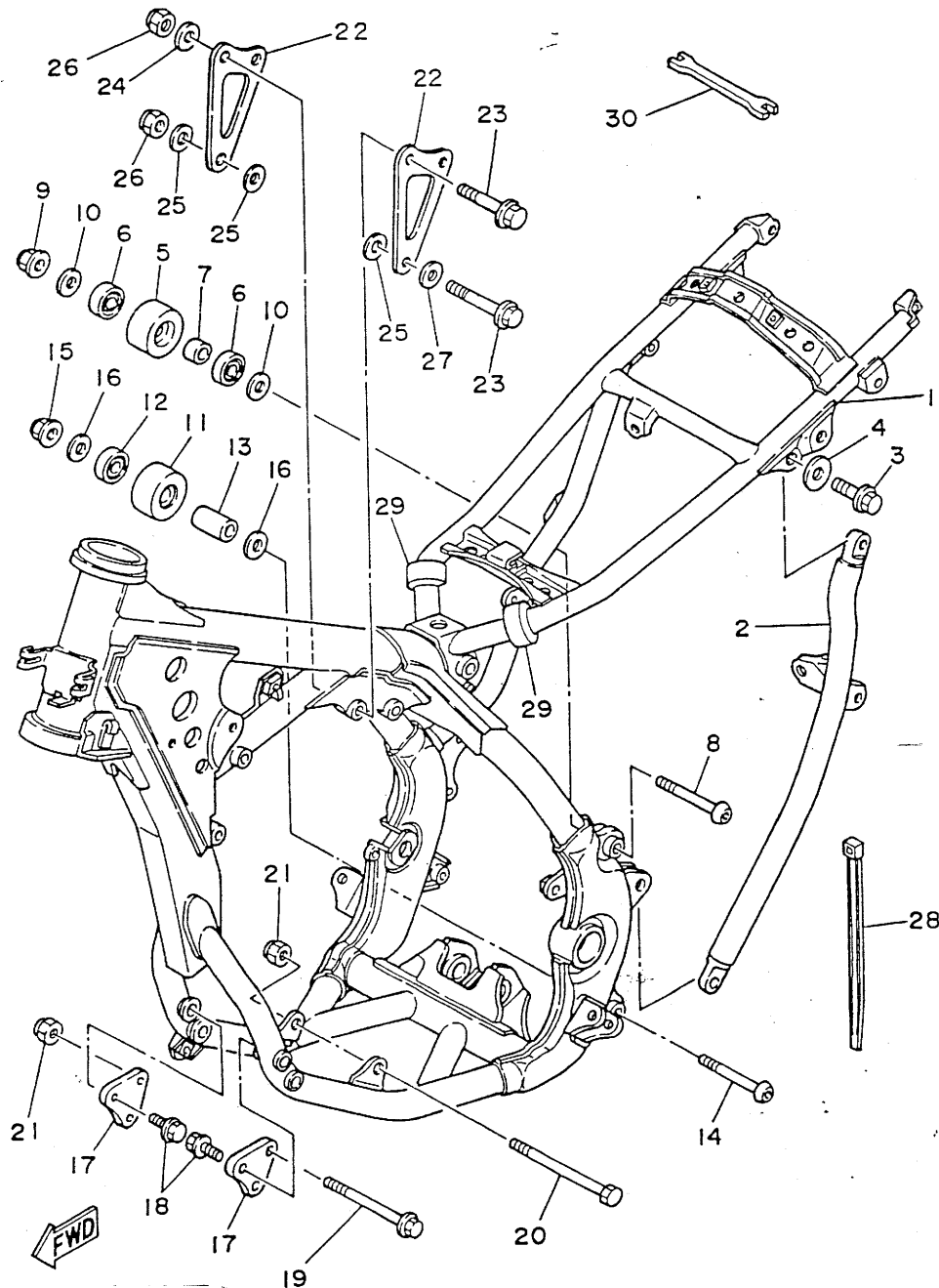

REF. NO.	PART NO.	DESCRIPTION	Q'TY	REMARKS
1	3XJ-21110-00-UJ	FRAME COMP.	1	RADICAL WHITE
2	3XK-21123-00-UJ	BACK, stay lh.	1	RADICAL WHITE
3	90101-08461	BOLT	2	
4	90201-080E2	WASHER, plate	2	
5	3JD-22178-00	TENSIONER	1	
6	93300-60816	BEARING	2	
7	90387-087K5	COLLAR	1	
8	92011-08070	SCREW	1	
9	95601-08200	NUT, self-locking	1	
10	90201-081A6	WASHER, plate	2	
11	3JD-22178-10	TENSIONER	1	
12	93300-60816	BEARING	1	
13	90387-086N4	COLLAR	1	
14	92011-08070	SCREW	1	
15	95601-08200	NUT, self-locking	1	
16	90201-081A6	WASHER, plate	2	
17	1LX-21419-01	BRACKET, engine 2	2	
18	91011-08040	BOLT, flange	4	
19	95811-08095	BOLT, flange	1	
20	90109-08386	BOLT	1	
21	95601-08200	NUT, self-locking	2	
22	1LX-21425-00	BRACKET, rear upper 1	2	
23	91011-08055	BOLT, flange	3	
24	90202-08022	WASHER, plate	2	
25	90201-085E6	WASHER, plate	3	
26	95601-08200	NUT, self-locking	3	
27	90201-084K3	WASHER, plate	1	
28	12R-82591-00	BAND	1	

FIG. 16 FRAME

REF. NO.	PART NO.	DESCRIPTION	Q'TY	REMARKS
----------	----------	-------------	------	---------

29	3XJ-21717-00	DAMPER, side cover	2	
30	56A-28166-00	WRENCH, hexagon	1	

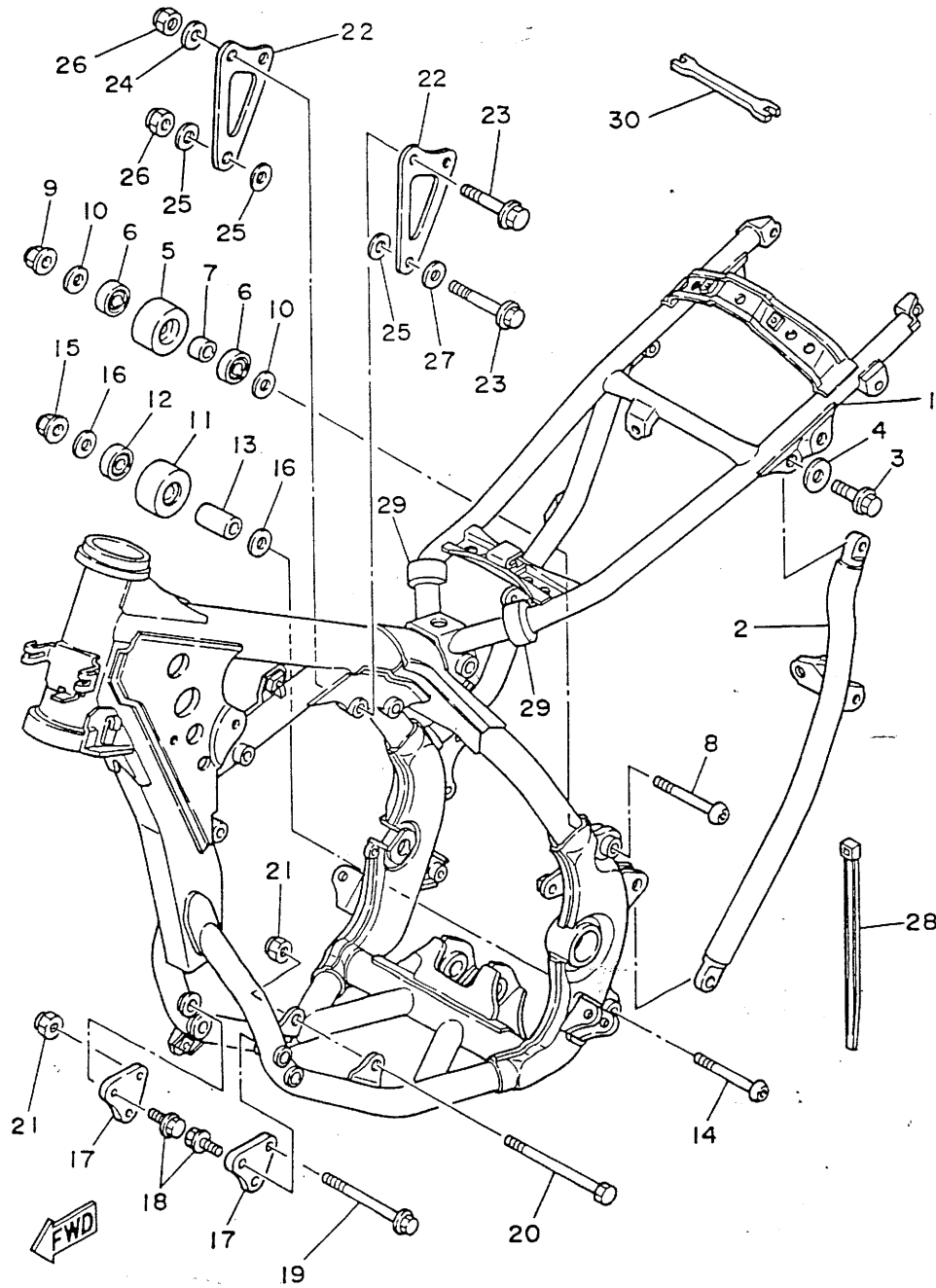
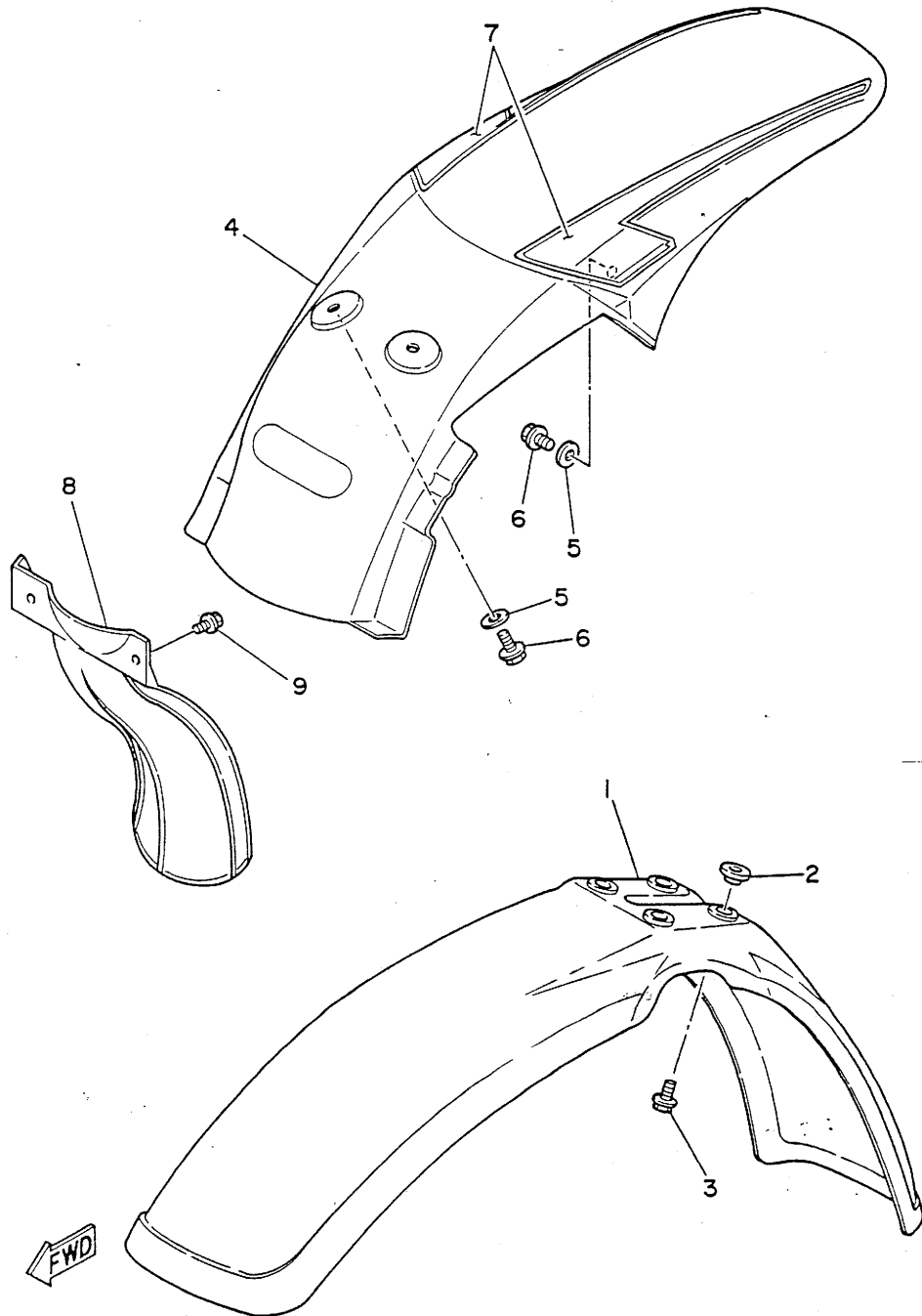
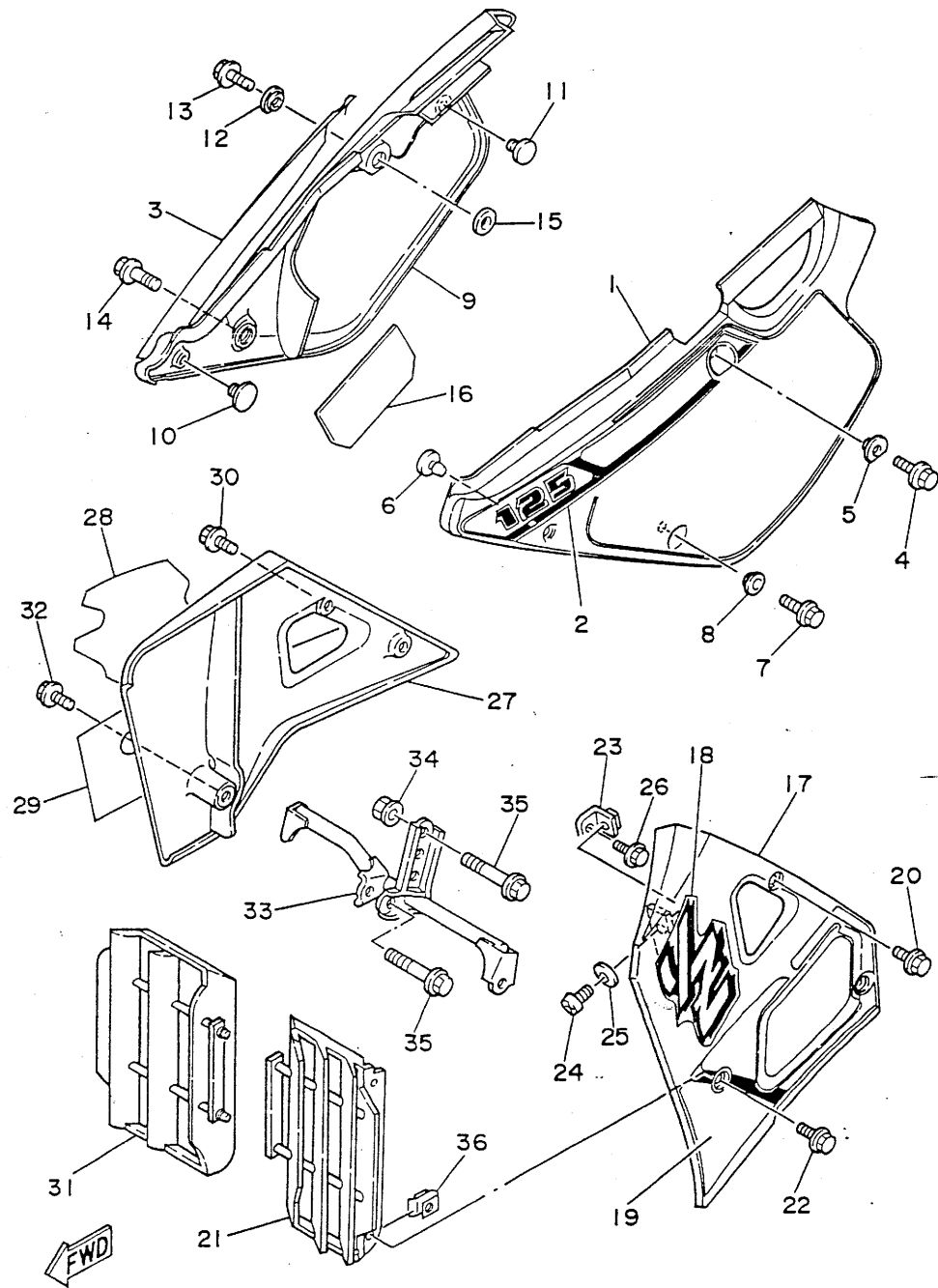

FIG. 17 FENDER



REF. NO.	PART NO.	DESCRIPTION	Q'TY	REMARKS
1	3XJ-21511-01	FENDER, front	1	
2	3JD-21748-00	COLLAR	4	
3	90119-06063	BOLT, with washer	4	
4	3XJ-21611-00	FENDER, rear	1	
5	90201-06571	WASHER, plate	4	
6	90105-06553	BOLT, washer based	4	
7	3XJ-2165A-01	GRAPHIC SET, rear fender	1	
8	39X-21642-00	GUARD, flap	1	
9	90119-06185	BOLT, with washer	2	

FIG. 18 SIDE COVER



REF. NO.	PART NO.	DESCRIPTION	Q'TY	REMARKS
1	3XJ-21711-00	COVER, side 1	1	
2	3XJ-2173L-00	GRAPHIC 1	1	
3	3XJ-2174L-00	GRAPHIC 2	1	
4	95023-08016	BOLT	1	
5	90387-084X5	COLLAR	1	
6	22W-24181-00	DAMPER, locating 1	1	
7	91021-06016	BOLT, flange	1	
8	90387-064X4	COLLAR	1	
9	3XJ-21721-00	COVER, side 2	1	
10	22W-24181-00	DAMPER, locating 1	1	
11	3JD-24181-00	DAMPER, locating 1	1	
12	90387-084X5	COLLAR	1	
13	95023-08016	BOLT	1	
14	91021-06012	BOLT, flange	1	
15	92901-08200	WASHER, plain	1	
16	3XJ-2174A-00	INSULATOR, side cover	1	
17	3XJ-21731-00	COVER, side 3	1	
18	3XJ-24244-00	GRAPHIC, fuel tank 1	1	
19	3XJ-24245-00	GRAPHIC, fuel tank 2	1	
20	90119-06192	BOLT, with washer	2	
21	3XJ-2172A-00	PANEL 1	1	
22	90119-05193	BOLT, with washer	1	
23	2VM-2172K-00	BRACKET 1	1	
24	98501-05016	SCREW, pan head	1	
25	92990-05200	WASHER, plain	1	
26	90119-05193	BOLT, with washer	1	
27	3XJ-21741-00	COVER, side 4	1	
28	3XJ-24248-00	GRAPHIC, fuel tank 5	1	

FIG. 18 SIDE COVER

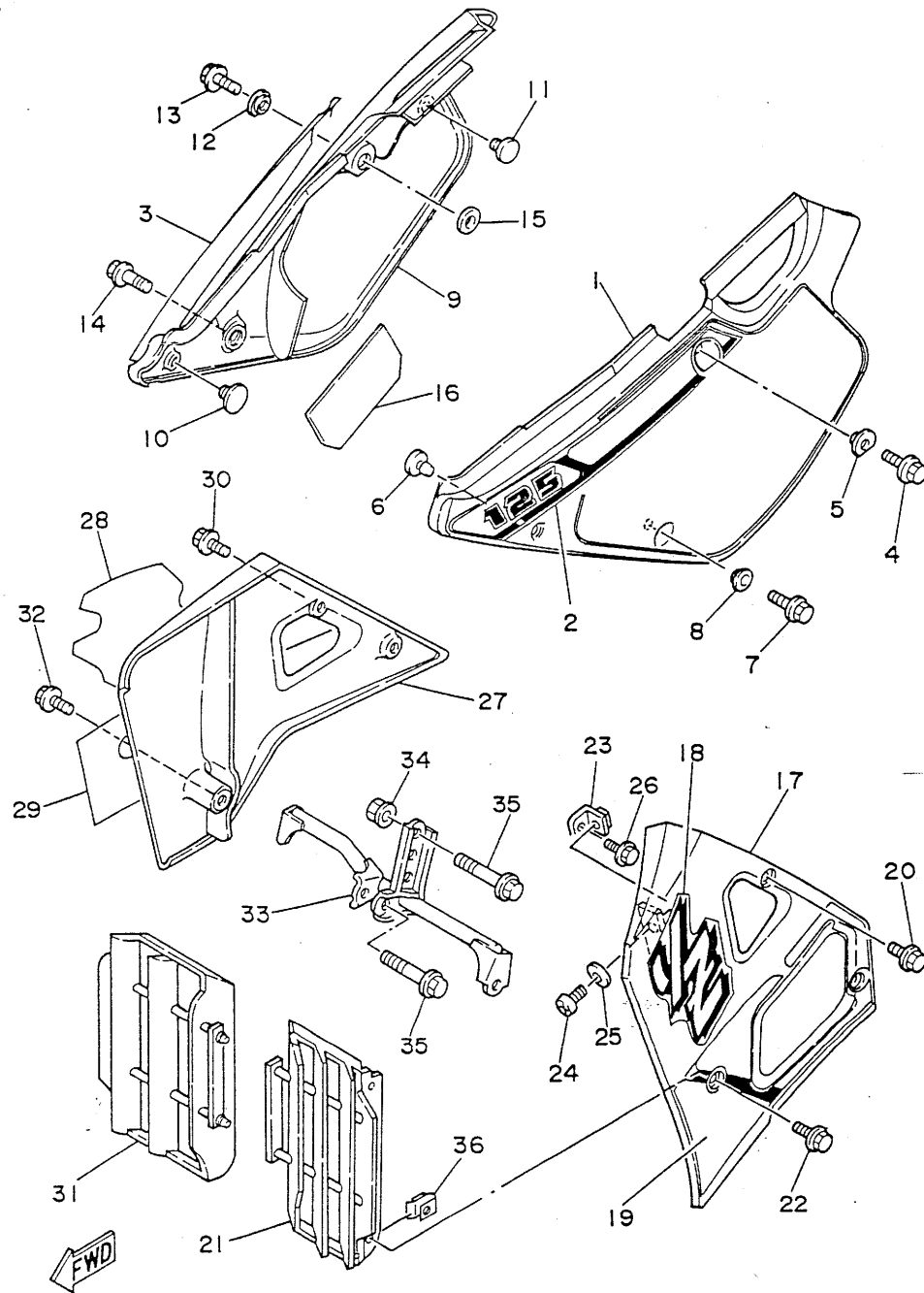

REF. NO.	PART NO.	DESCRIPTION	Q'TY	REMARKS
29	3XJ-24246-01	GRAPHIC, fuel tank 3	1	
30	90119-06192	BOLT, with washer	2	
31	3XJ-2172F-00	PANEL 2	1	
32	90119-05193	BOLT, with washer	2	
33	3JD-2174F-00	GUARD, radiator	1	
34	95701-08500	NUT, flange	1	
35	95023-08050	BOLT	2	
36	22W-21791-00	NUT	4	

FIG. 19 REAR ARM

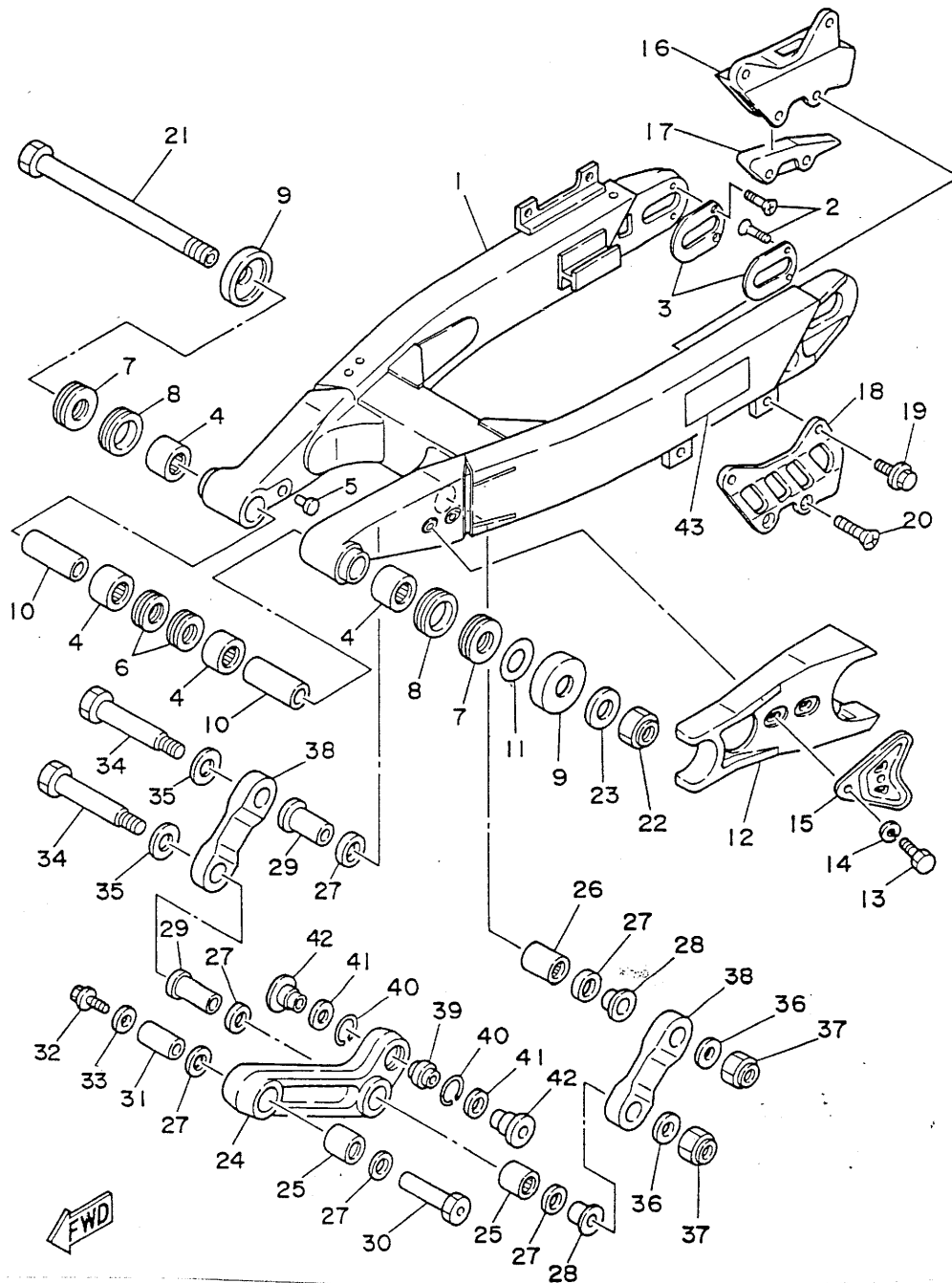

REF. NO.	PART NO.	DESCRIPTION	Q'TY	REMARKS
1	3XJ-22110-01	REAR ARM COMP.	1	
2	98701-04010	SCREW, flat head	4	
3	3XJ-22355-00	PATCH A	2	
4	93317-22263	BEARING, cylindrical	4	
5	90338-10150	PLUG	2	
6	93106-22019	OIL SEAL (DC 22-28-8)	2	
7	93342-22208	BEARING, thrust	2	
8	93108-35004	OIL SEAL (35-41-8)	2	
9	3R4-22129-00	COVER, thrust 2	2	
10	90380-16056	BUSH, solid	2	
11	156-22127-00	SHIM (0.3T)	1	
12	3JD-22151-00	SEAL, guard	1	
13	95023-06020	BOLT	2	
14	92990-06100	WASHER, spring	2	
15	3JD-22156-00	WASHER, plate	1	
16	3JD-22199-00	SUPPORT, chain	1	
17	3JD-22147-00	PROTECTOR, chain	1	
18	3JD-22128-00	COVER, thrust 1	1	
19	91001-06020	BOLT, flange	2	
20	98701-06035	SCREW, flat head	2	
21	1LX-22141-00	SHAFT, pivot	1	
22	90185-16127	NUT, self-locking	1	
23	90201-164H4	WASHER, plate	1	
24	3XJ-2217A-00	ARM, relay	1	
25	93315-22046	BEARING, cylindrical	2	
26	93315-22046	BEARING, cylindrical	1	
27	93109-20029	OIL SEAL	6	

FIG. 19 REAR ARM

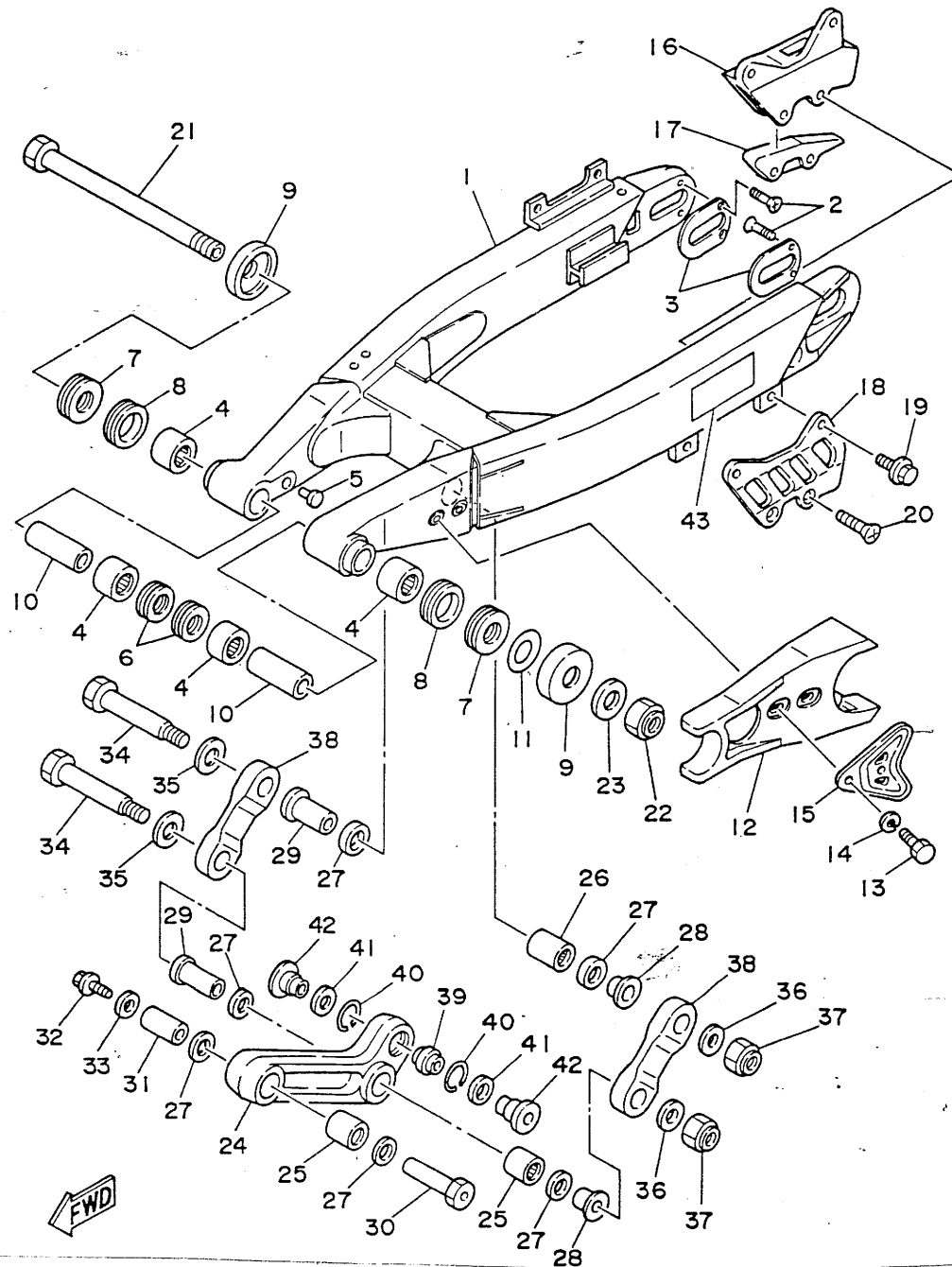

REF. NO.	PART NO.	DESCRIPTION	Q'TY	REMARKS
28	90387-164N2	COLLAR	2	
29	90387-164N3	COLLAR	2	
30	90179-10544	NUT	1	
31	90387-167R5	COLLAR	1	
32	91011-10016	BOLT, flange	1	
33	90201-106F2	WASHER, plate	1	
34	90109-142F4	BOLT	2	
35	90201-164H4	WASHER, plate	2	
36	90201-14740	WASHER, plate	2	
37	90185-14070	NUT, self-locking	2	
38	3XJ-2217F-00	ROD, connecting 1	2	
39	93399-99921	BEARING	1	
40	93440-30113	CIRCLIP	2	
41	3XJ-22475-00	SEAL, dust	2	
42	90387-103X9	COLLAR	2	
43	3XJ-2218A-00	EMBLEM, rear arm	2	

FIG. 20 REAR SUSPENSION

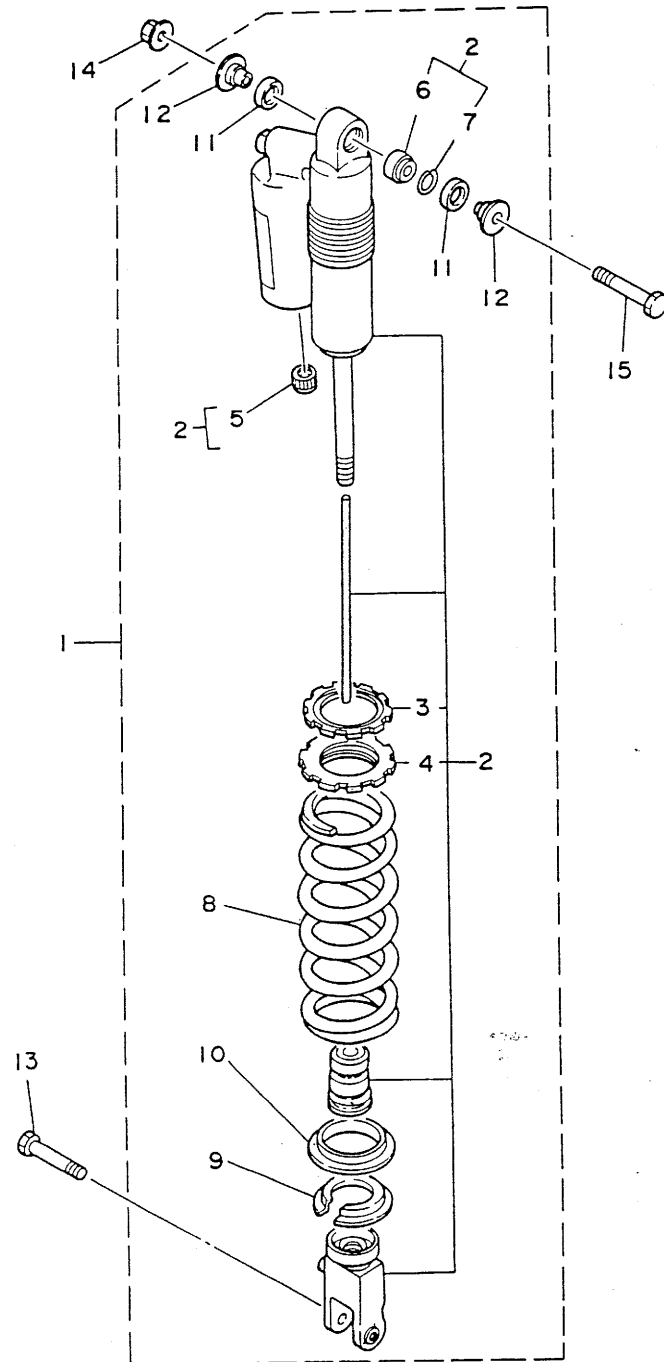

REF. NO.	PART NO.	DESCRIPTION	Q'TY	REMARKS
1	3XJ-22210-00	SHOCK ABSORBER ASSY, rear	1	
2	3XJ-22201-00	.DAMPER SUB ASSY	1	
3	3SP-22234-00	..GUIDE, spring 3	1	
4	3SP-22213-00	..SEAT, spring upper	1	
5	3JD-22417-00	..PLUG	1	
6	3JD-22216-00	..BUSH, rear shock absorber	1	
7	3JD-22215-00	..RING, cover	1	
8	3XJ-22212-70	.SPRING (K=4.6)	1	
9	3JD-22214-00	.GUIDE, spring 1	1	
10	3JD-22224-00	.GUIDE, spring 2	1	
11	3JD-22475-00	.SEAL, dust	2	
12	3XJ-22253-00	.COLLAR, distance	2	
13	90105-10614	BOLT, washer based	1	
14	95611-10200	NUT, self-locking	1	
15	3SP-22241-00	BOLT 1	1	

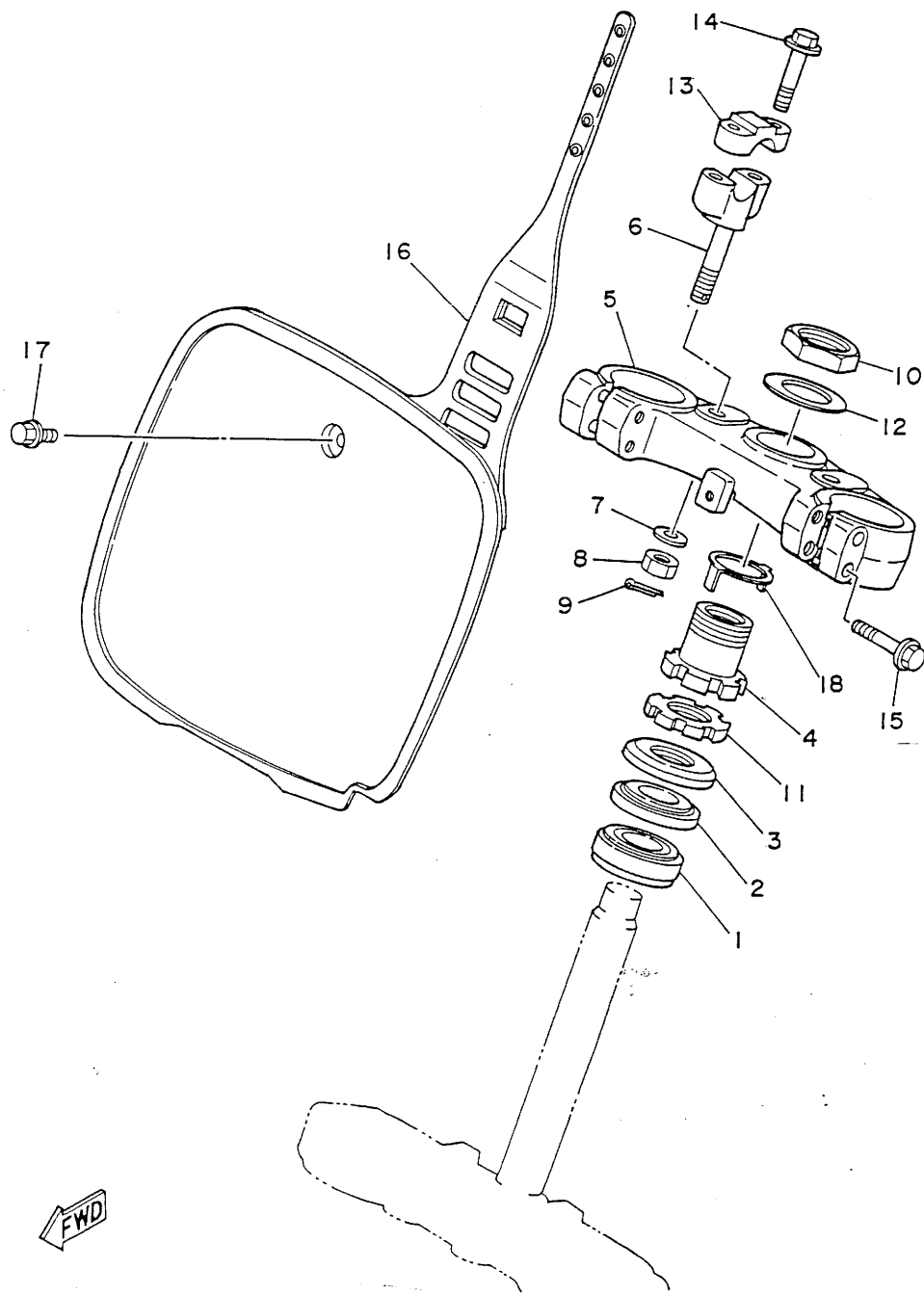
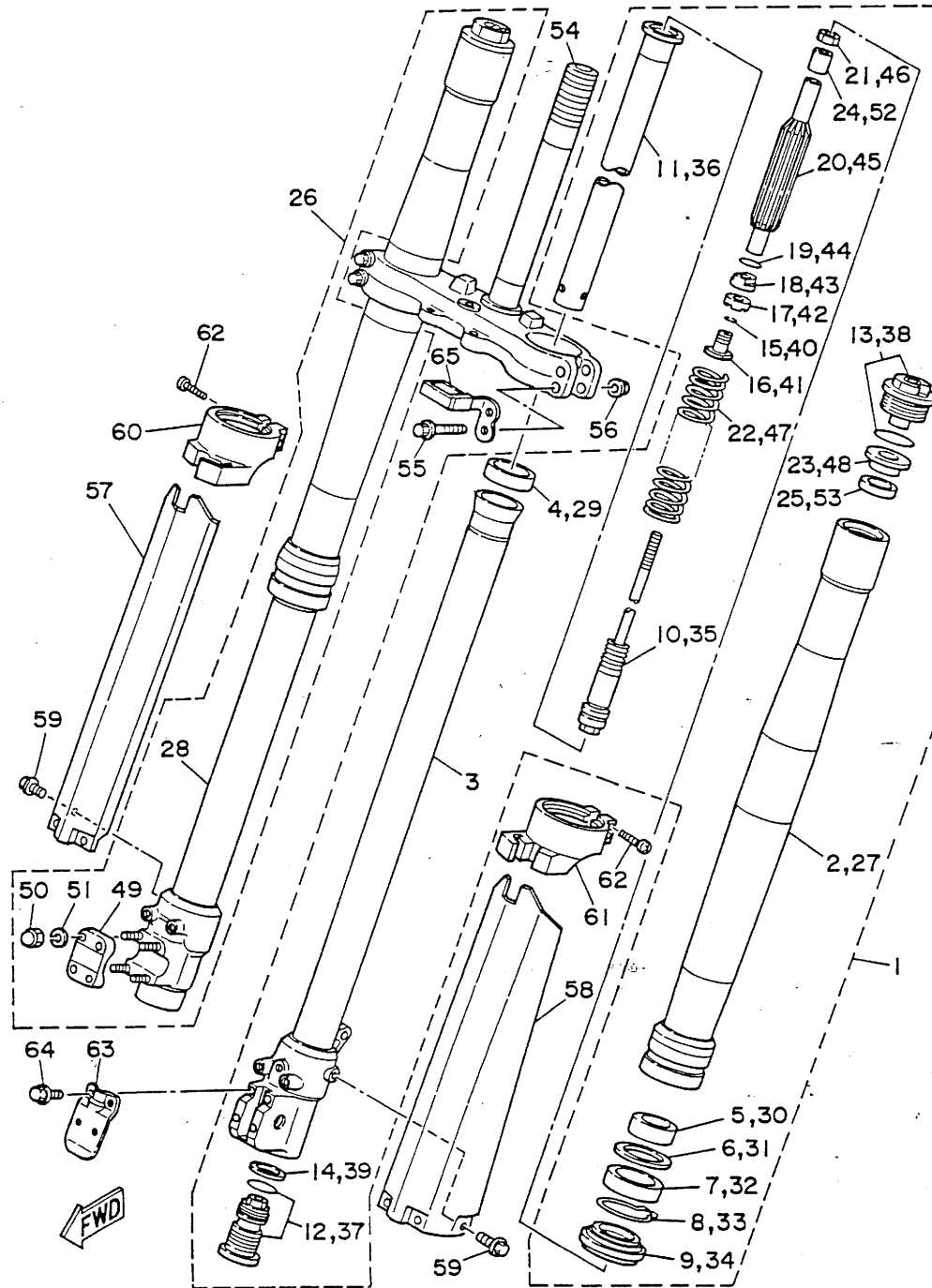

FIG. 21 STEERING

REF. NO.	PART NO.	DESCRIPTION	Q'TY	REMARKS
1	93332-00067	BEARING	1	
2	93332-00068	BEARING	1	
3	2HG-23416-00	COVER, ball race 2	1	
4	90179-28603	NUT	1	
5	3XJ-23435-00	CROWN, handle	1	
6	3SR-23442-00	HOLDER, handle lower	2	
7	92990-12200	WASHER, plain	2	
8	95611-12100	NUT, u	2	
9	91401-25020	PIN, cotter	2	
10	90170-36394	NUT	1	
11	90179-28602	NUT	1	
12	90201-365M5	WASHER, plate	1	
13	3SP-23441-00	HOLDER, handle upper	2	
14	95023-08035	BOLT	4	
15	95023-08050	BOLT	4	
16	3XJ-23485-01	PLATE, number	1	
17	90119-06185	BOLT, with washer	1	
18	3SP-23418-00	WASHER, special	1	

FWD

FIG. 22 FRONT FORK



REF. NO.	PART NO.	DESCRIPTION	Q'TY	REMARKS
1	3XJ-23102-L0	FRONT FORK ASSY (L.H)	1	
2	3XJ-23136-L0	.TUBE, outer 2	1	
3	3XJ-23120-L0	.INNER TUBE COMP.2	1	
4	3XJ-23171-L0	.PISTON, front fork	1	
5	3XJ-23125-L0	.METAL, slide 1	1	
6	4V4-23146-L0	.WASHER, oil seal	1	
7	3XJ-23145-L0	.OIL SEAL	1	
8	4V4-23153-L0	.RING, snap	1	
9	3XJ-23144-L0	.SEAL, dust	1	
10	3XJ-2314A-L0	.PISTON ROD ASSY	1	
11	3XJ-23170-L0	.CYLINDER COMP., front fork	1	
12	3XJ-2316A-L0	.VALVE COMP.	1	
13	3XJ-23111-L0	.BOLT, cap	1	
14	2HH-23158-L0	.GASKET	1	
15	3XJ-23153-L0	.RING, snap	2	
16	3XJ-23113-L0	.COLLAR	1	
17	3XJ-23166-L0	.SPACER, oil lock	1	
18	3XJ-23778-L0	.NUT	1	
19	36Y-23147-10	.O-RING	1	
20	3XJ-23142-L0	.SEAT, spring upper	1	
21	3XJ-23357-L0	.NUT	1	
22	3XJ-23141-L0	.SPRING, front fork (K=0.365)	1	
23	3XJ-23143-L0	.SEAT, spring lower	1	
24	3XJ-23363-L0	.COLLAR 1	1	
25	NOT APPLICABLE			
26	3XJ-23103-L0	FRONT FORK ASSY (R.H)	1	

FIG. 22 FRONT FORK

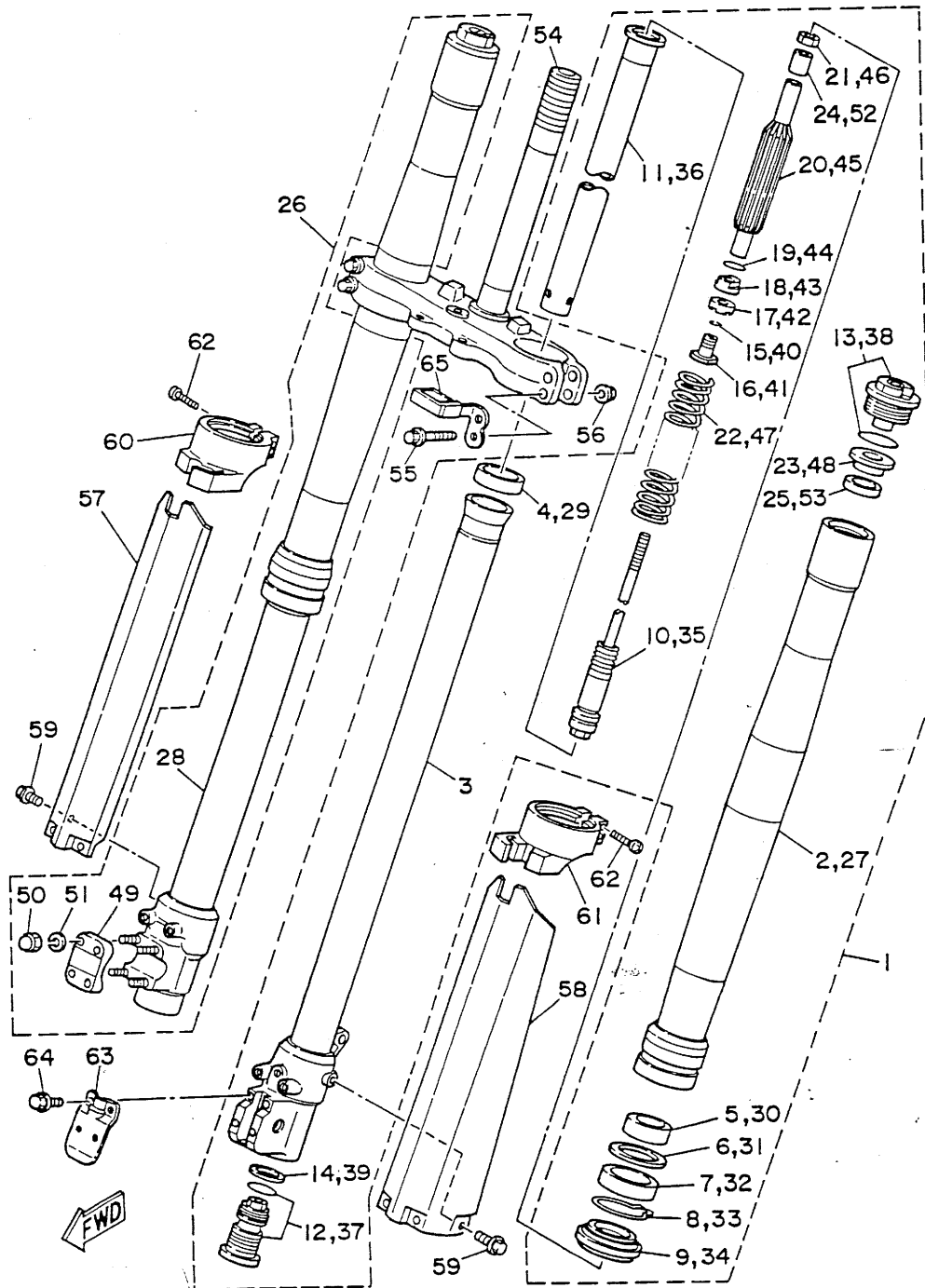

REF. NO.	PART NO.	DESCRIPTION	Q'TY	REMARKS
26	NUT APPLICABLE			
27	3XJ-23136-L0	.TUBE, outer 2	1	
28	3XJ-23110-L0	.INNER TUBE COMP.1	1	
29	3XJ-23171-L0	.PISTON, front fork	1	
30	3XJ-23125-L0	.METAL, slide 1	1	
31	4V4-23146-L0	.WASHER, oil seal	1	
32	3XJ-23145-L0	.OIL SEAL	1	
33	4V4-23153-L0	.RING, snap	1	
34	3XJ-23144-L0	.SEAL, dust	1	
35	3XJ-2314A-L0	.PISTON ROD ASSY	1	
36	3XJ-23170-L0	.CYLINDER COMP., front fork	1	
37	3XJ-2316A-L0	.VALVE COMP.	1	
38	3XJ-23111-L0	.BOLT, cap	1	
39	2HH-23158-L0	.GASKET	1	
40	3XJ-23153-L0	.RING, snap	2	
41	3XJ-23113-L0	.COLLAR	1	
42	3XJ-23166-L0	.SPACER, oil lock	1	
43	3XJ-23778-L0	.NUT	1	
44	36Y-23147-10	.O-RING	1	
45	3XJ-23142-L0	.SEAT, spring upper	1	
46	3XJ-23357-L0	.NUT	1	
47	3XJ-23141-L0	.SPRING, front fork (K=0.365)	1	
48	3XJ-23143-L0	.SEAT, spring lower	1	
49	3XJ-23167-L0	.HOLDER, axle	1	
50	5Y3-23393-00	.NUT, special	4	
51	92990-06100	.WASHER, spring	4	
52	3XJ-23363-L0	.COLLAR 1	1	

FIG. 22 FRONT FORK

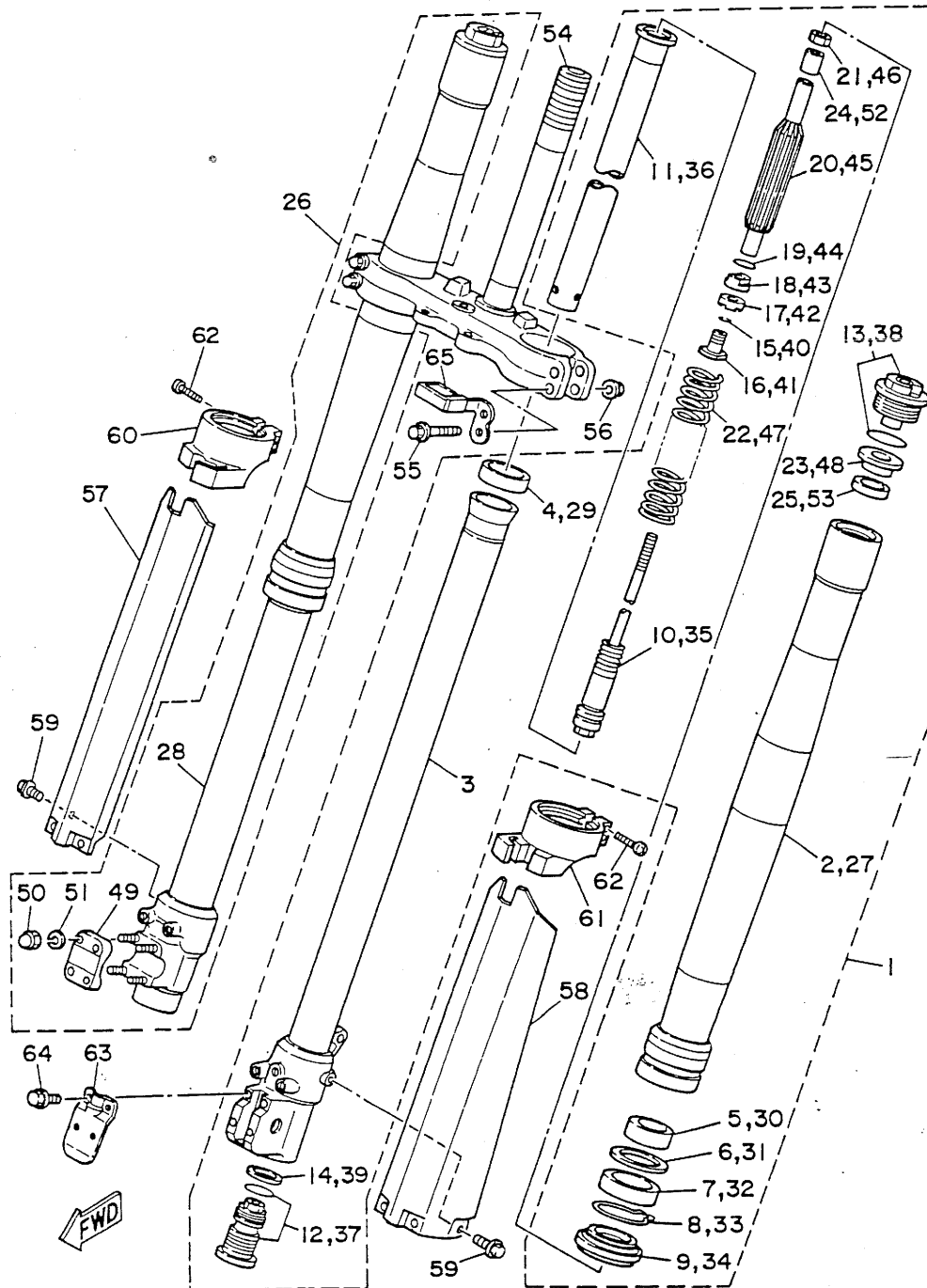

REF. NO.	PART NO.	DESCRIPTION	Q'TY	REMARKS
53	NOT APPLICABLE		1	
54	3XJ-23340-L0	UNDER BRACKET COMP.	1	
55	95021-08060	BOLT, flange	4	
56	95701-08500	NUT, flange	4	
57	3XJ-2314J-L0	PROTECTOR COMP., 2	1	
58	3XJ-2314H-L0	PROTECTOR COMP., 1	1	
59	3SP-23356-L0	BOLT 2	6	
60	3SP-2314G-L0	PROTECTOR GUIDE COMP., 2	1	
61	3SP-2314F-L0	PROTECTOR GUIDE COMP., 1	1	
62	3XJ-23194-L0	SCREW, boot band	4	
63	3SP-2314E-L0	COVER, hose	1	
64	3SP-23346-L0	BOLT 1	4	
65	3JD-23389-01	GUIDE, cable	1	

FIG. 23 FUEL TANK

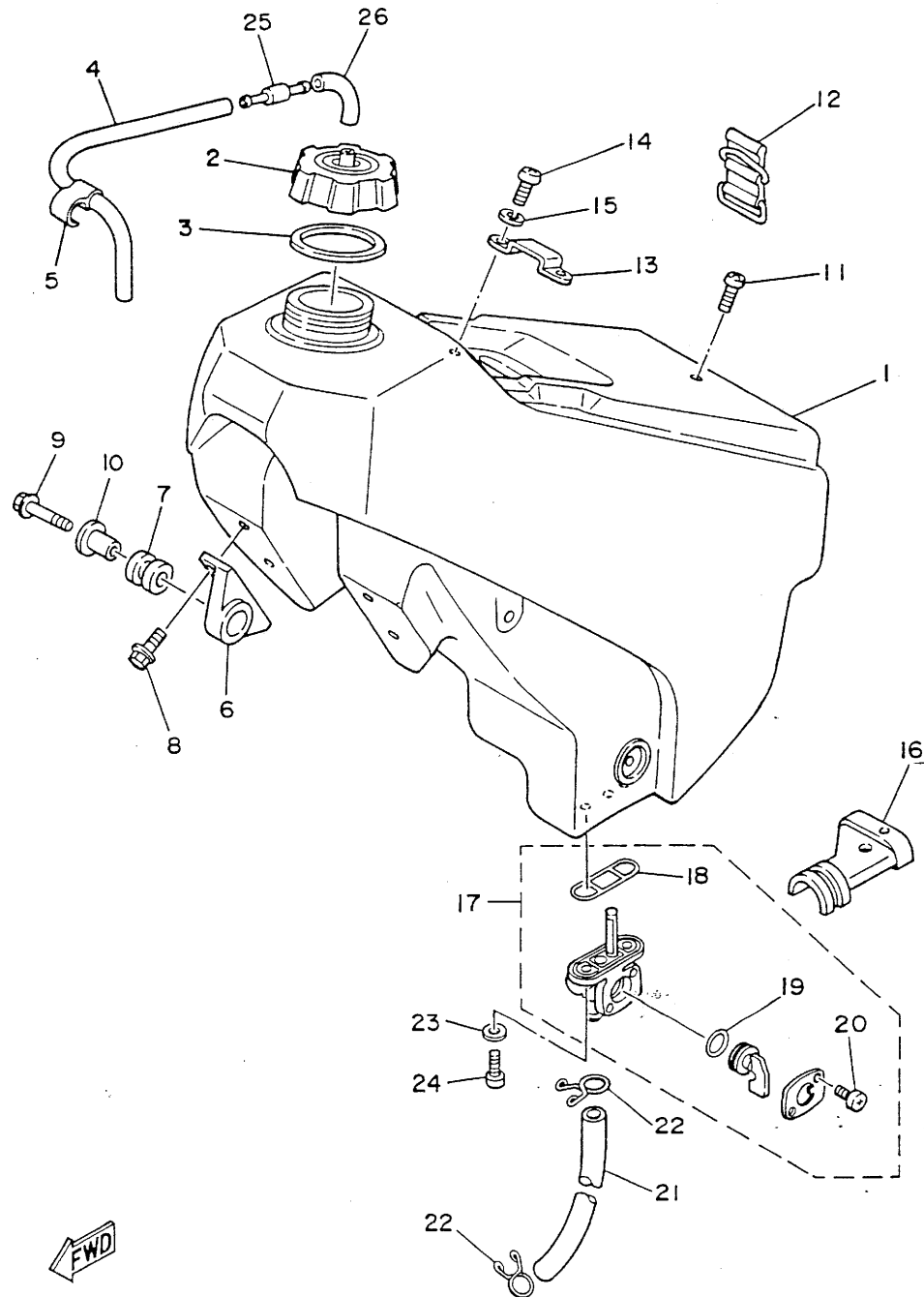

REF. NO.	PART NO.	DESCRIPTION	Q'TY	REMARKS
1	3XJ-24110-00	FUEL TANK COMP.	1	
2	5X7-24611-01	BODY, cap	1	
3	5X7-24612-00	GASKET, cap	1	
4	90445-09100	HOSE	1	
5	90468-15064	CLIP	1	
6	24X-24144-00	HOLDER, damper	2	
7	90480-18354	GROMMET	2	
8	95023-06016	BOLT	4	
9	95023-06035	BOLT	2	
10	3JD-24186-00	WASHER, special	2	
11	98980-06020	SCREW, bind	1	
12	3SP-24173-00	BAND, tank fitting 1	1	
13	5X6-2412F-00	BRACKET, seat	1	
14	97003-06012	BOLT	2	
15	92990-06100	WASHER, spring	2	
16	1LX-24181-00	DAMPER, locating 1	1	
17	3JD-24500-00	FUEL COCK ASSY 1	1	
18	4X8-24512-00	.O-RING	1	
19	4X8-24534-00	.SEAL, cock	1	
20	98503-03008	.SCREW, pan head	2	
21	90445-11452	HOSE	1	
22	90467-10008	CLIP	2	
23	90202-05193	WASHER, plate	2	
24	90149-06011	SCREW	2	
25	3XJ-24380-00	PIPE JOINT ASSY	1	
26	90445-09058	HOSE	1	

FIG. 24 SEAT

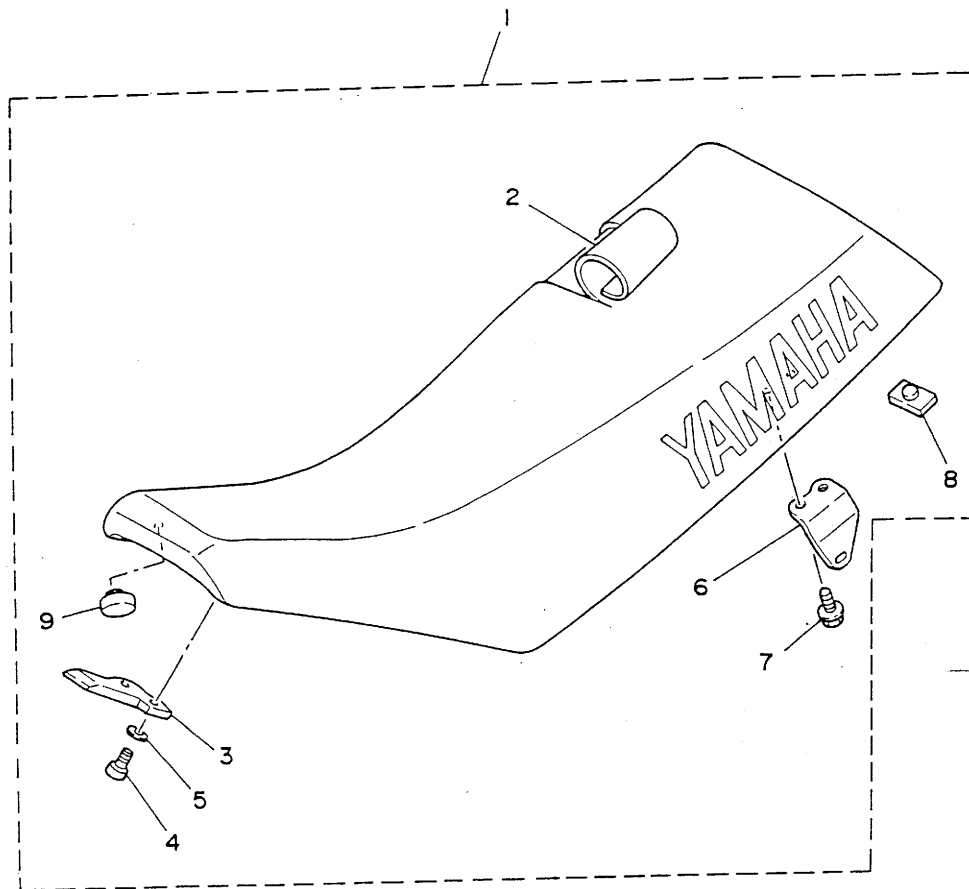

REF. NO.	PART NO.	DESCRIPTION	Q'TY	REMARKS
1	3XJ-24770-00	SEMI-DOUBLE SEAT ASSY	1	
2	3XJ-24731-00	.COVER, seat	1	
3	5X6-24748-10	.BRACKET, seat	1	
4	98501-06012	.SCREW, pan head	2	
5	92901-06600	.WASHER, plate	2	
6	1LX-24738-01	.BRACKET, seat	2	
7	95023-06012	.BOLT	4	
8	509-24724-00	.DAMPER, seat	1	
9	3L7-24724-00	.DAMPER, seat	2	

FWD

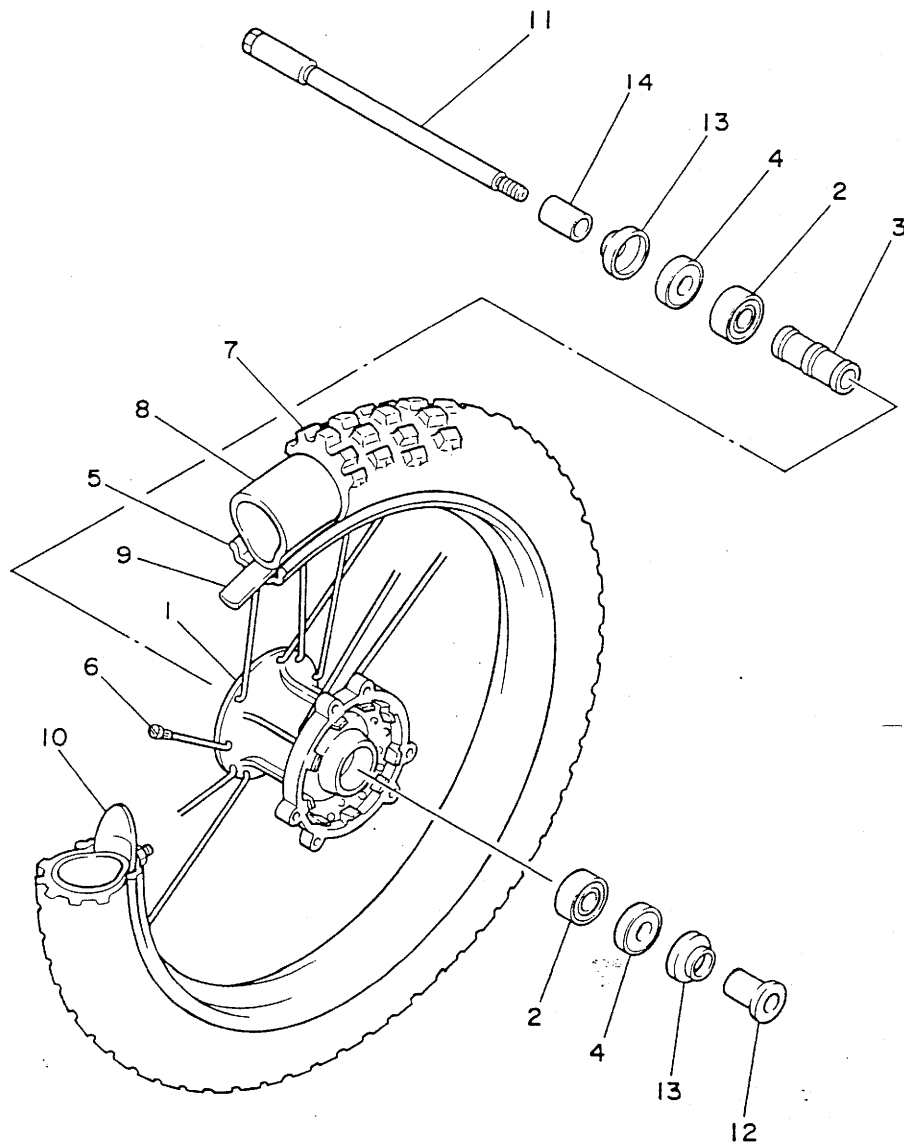

FWD

FIG. 25 FRONT WHEEL

REF. NO.	PART NO.	DESCRIPTION	Q'TY	REMARKS
1	3SP-25111-00	HUB, front	1	
2	93306-20209	BEARING	2	
3	90560-15352	SPACER	1	
4	93102-20281	OIL SEAL	2	
5	94416-21453	RIM (1.60-21)	1	
6	1LX-25104-00	SPOKE SET, front	1	
7	80/100 x 21	TIRE	1	BRIDGESTONE M51
8	275 x 21	TUBE	1	
9	94307-21145	BAND, rim	1	
10	5X2-25394-00	SPACER, bead	1	
11	55U-25181-01	AXLE, wheel	1	
12	90387-152V1	COLLAR	1	
13	322-25118-00	COVER, hub dust	2	
14	90387-151V9	COLLAR	1	

FIG. 26 FRONT BRAKE CALIPER

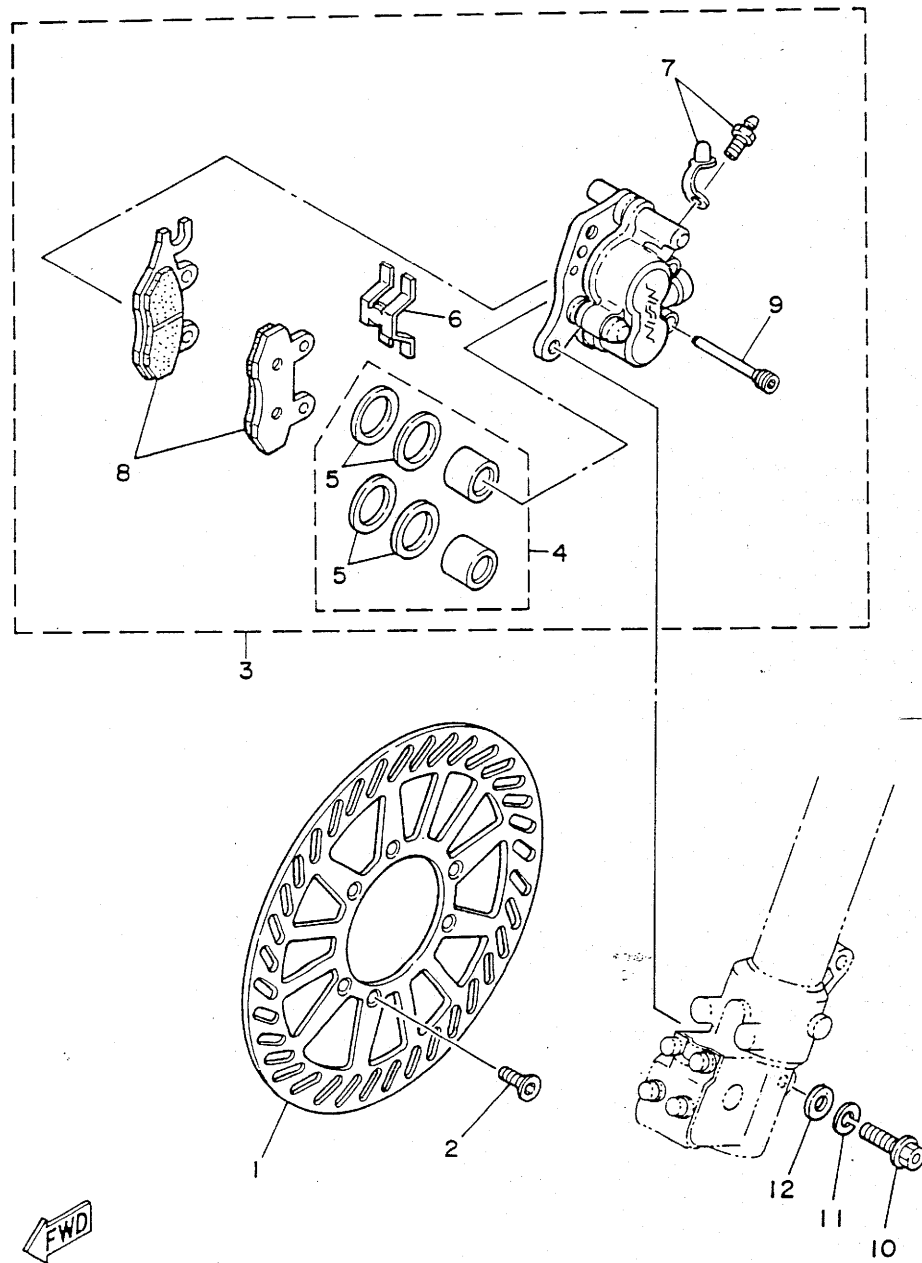

REF. NO.	PART NO.	DESCRIPTION	Q'TY	REMARKS
1	3SP-2582T-00	DISC, brake	1	
2	90149-06272	SCREW	6	
3	3SP-2580T-00	CALIPER ASSY (LEFT)	1	
4	3JD-W0057-00	.PISTON ASSY, caliper	1	
5	3JD-W0047-00	..CALIPER SEAL KIT	1	
6	3JD-25919-00	.SUPPORT, pad	1	
7	1UY-W0048-50	.BREED SCREW KIT	1	
8	3SP-W0045-00	.BRAKE PAD KIT	1	
9	3GD-25933-00	.PIN, pad	2	
10	97301-08040	BOLT	2	
11	92990-08100	WASHER, spring	2	
12	92901-08600	WASHER, plate	2	

FIG. 27 REAR WHEEL

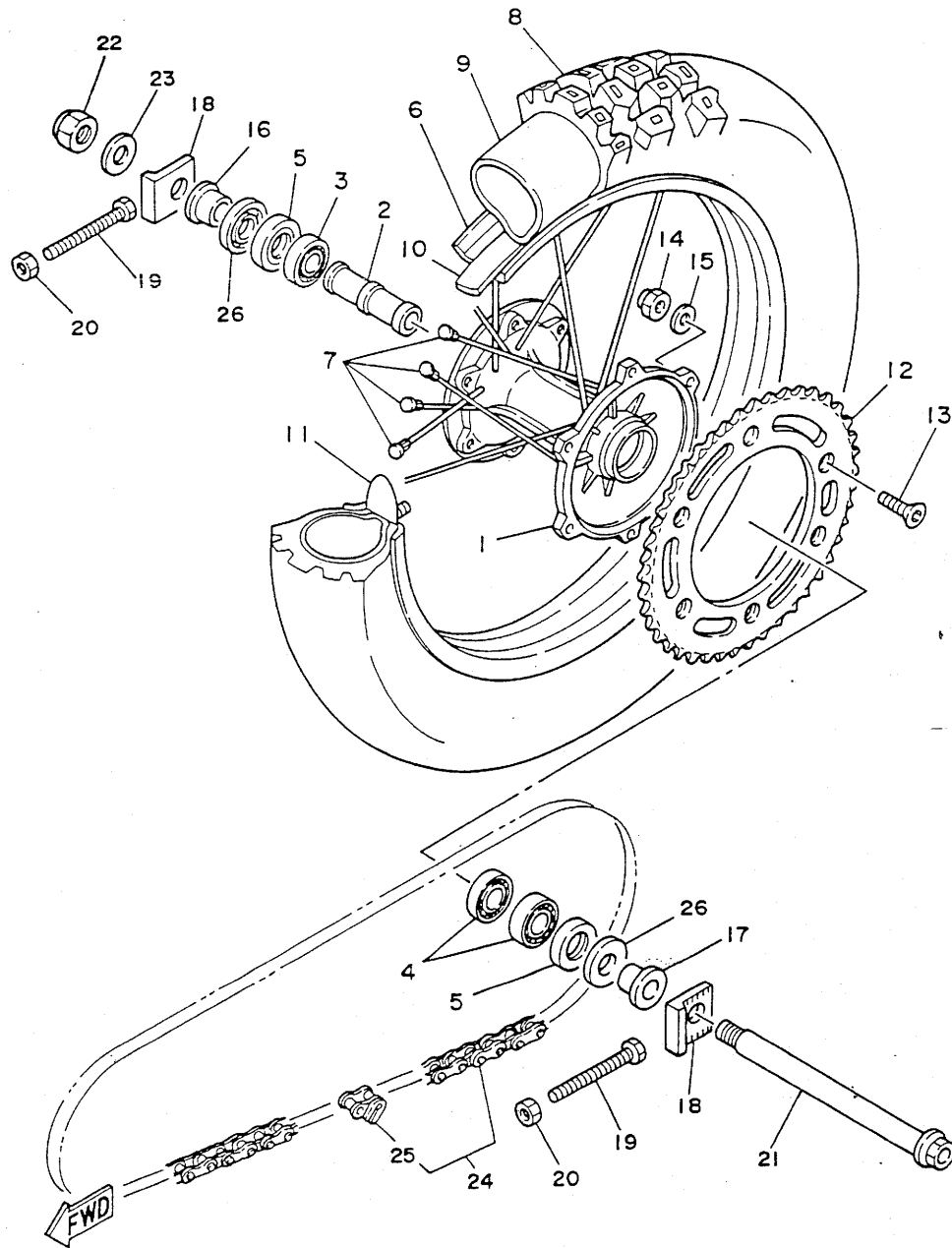

REF. NO.	PART NO.	DESCRIPTION	Q'TY	REMARKS
1	3SP-25311-00	HUB, rear	1	
2	3JD-25317-01	SPACER, bearing	1	
3	93306-00418	BEARING	1	
4	93306-00438	BEARING	2	
5	93106-28023	OIL SEAL	2	
6	94418-19485	RIM (1.85-19)	1	
7	3JD-25304-00	SPOKE SET, rear	1	
8	100/90 x 19	TIRE	1	BRIDGESTONE M40
9	275/300 x 19	TUBE	1	
10	275 x 19	BAND, rim	1	
11	2X3-25394-00	SPACER, bead	2	
12	3JD-25451-01	SPROCKET, driven (51T)	1	STD
	39W-25444-01	SPROCKET, driven (44T)	1	AP
	39W-25445-01	SPROCKET, driven (45T)	1	AP
	39W-25446-01	SPROCKET, driven (46T)	1	AP
	39W-25448-00	SPROCKET, driven (48T)	1	AP
	39W-25450-00	SPROCKET, driven (50T)	1	AP
	39W-25452-01	SPROCKET, driven (52T)	1	AP
	2HH-25449-00	SPROCKET, driven (49T)	1	AP
13	90109-08792	BOLT	6	
14	95611-08100	NUT, u	6	
15	90201-081A6	WASHER, plate	6	
16	90387-203V0	COLLAR	1	
17	90387-200Y5	COLLAR	1	

FIG. 27 REAR WHEEL

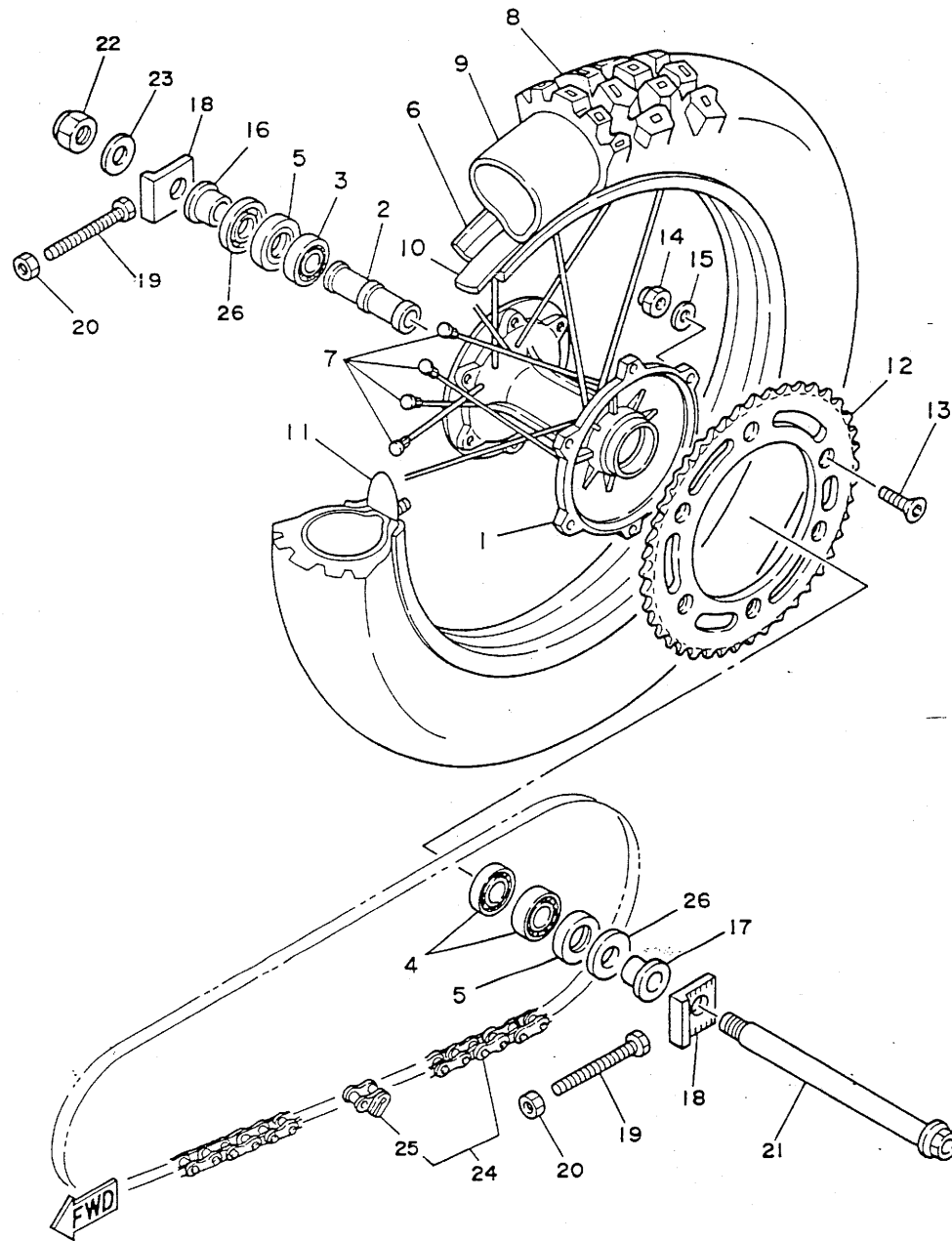

REF. NO.	PART NO.	DESCRIPTION	Q'TY	REMARKS
18	3SP-25388-00	PULLER, chain 1	2	
19	90101-08699	BOLT	2	
20	95701-08500	NUT, flange	2	
21	3JD-25381-01	AXLE, wheel	1	
22	90185-18104	NUT, self-locking	1	
23	92990-18600	WASHER	1	
24	94581-13116	CHAIN	1	
25	94681-13001	.JOINT, chain	1	
26	4V4-25367-00	COVER, hub dust	2	

FIG. 28 REAR BRAKE CALIPER

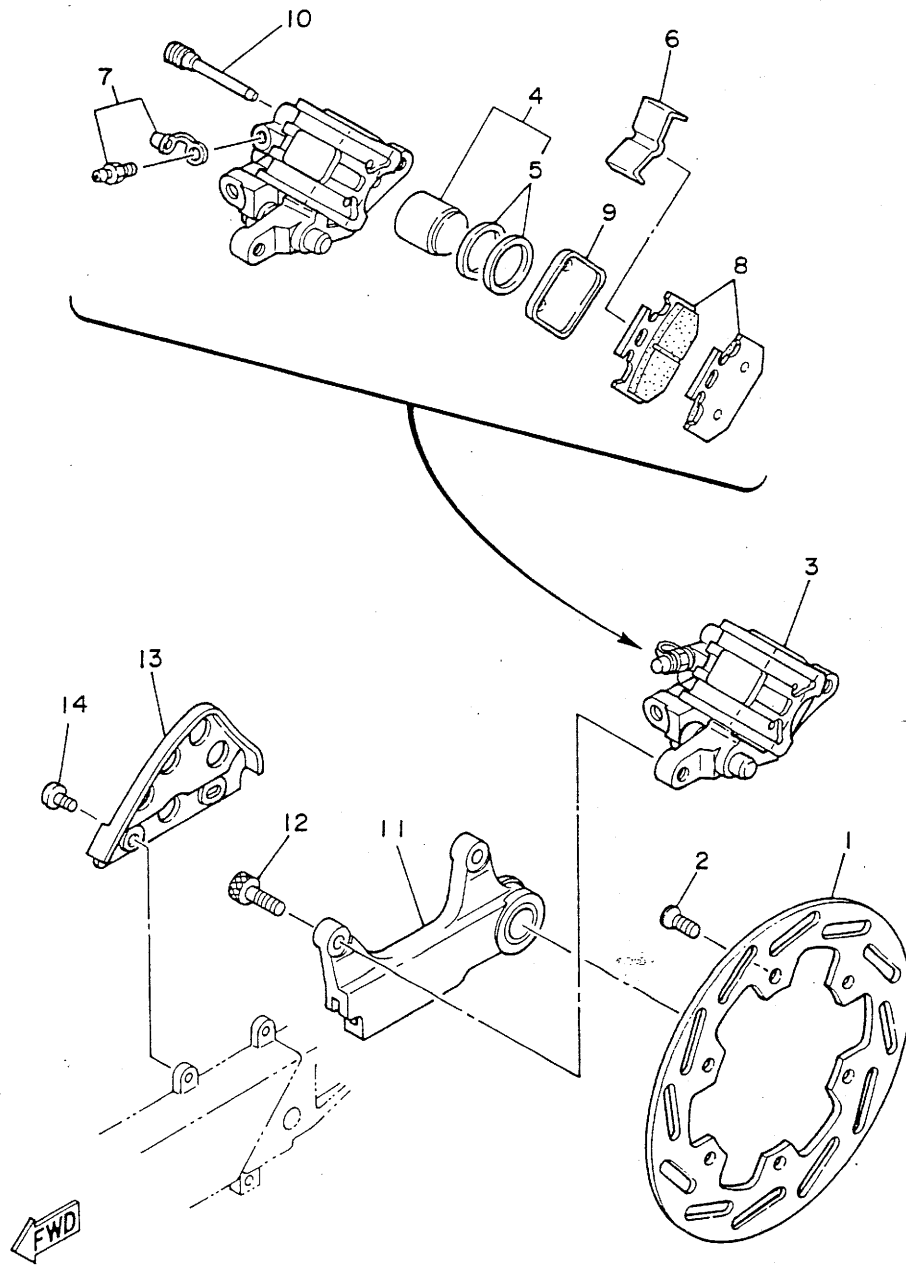

REF. NO.	PART NO.	DESCRIPTION	Q'TY	REMARKS
1	3XJ-2582W-00	DISC, rear brake 2	1	
2	90149-06272	SCREW	6	
3	3XJ-2580W-00	CALIPER ASSY, rear 2	1	
4	3SP-W0057-50	.PISTON ASSY, caliper	1	
5	3JD-W0047-50	..CALIPER SEAL KIT	1	
6	3SP-25919-51	.SUPPORT, pad	1	
7	1UY-W0048-50	.BREED SCREW KIT	1	
8	3XJ-W0046-00	.BRAKE PAD KIT, 2	1	
9	3GD-25827-00	..SHIM, caliper	1	
10	3SP-25924-51	.PIN, pad	2	
11	3XJ-25920-00	SUPT. BRKT. ASSY.	1	
12	91311-08025	BOLT	2	
13	3JD-27491-00	PROTECTOR	1	
14	92011-06012	SCREW	2	

FIG. 29 STEERING HANDLE. CABLE

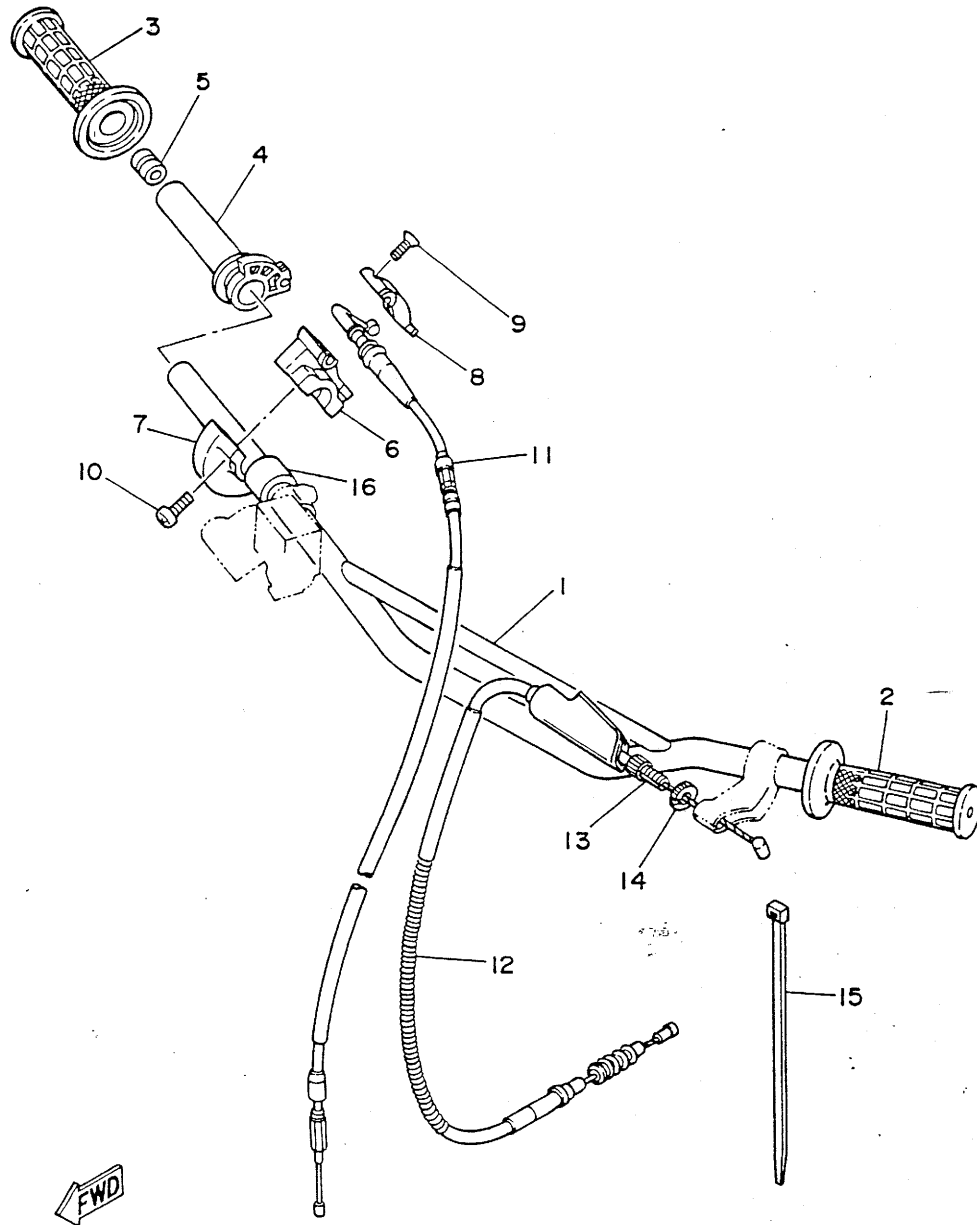

REF. NO.	PART NO.	DESCRIPTION	Q'TY	REMARKS
1	3XJ-26111-00	HANDLEBAR	1	
2	1LX-26241-01	GRIP (LEFT)	1	
3	1LX-26242-01	GRIP (RIGHT)	1	
4	23X-26243-00	TUBE, throttle guide	1	
5	688-82535-00	GROMMET	1	
6	23X-26281-00	CAP, grip upper	1	
7	431-26282-01-98	CAP, grip lower	1	LOW GLOSS BLACK
8	5X2-2628H-01	CAP, wire	1	
9	98706-04012	SCREW, flat head	2	
10	98506-05016	SCREW, pan head	2	
11	3JD-26311-00	CABLE, throttle 1	1	
12	3XJ-26335-00	CABLE, clutch	1	
13	90123-08090	BOLT	1	
14	90179-08401	NUT	1	
15	90465-13154	CLAMP	1	
16	90560-22281	SPACER	1	

FIG. 30 FRONT MASTER CYLINDER

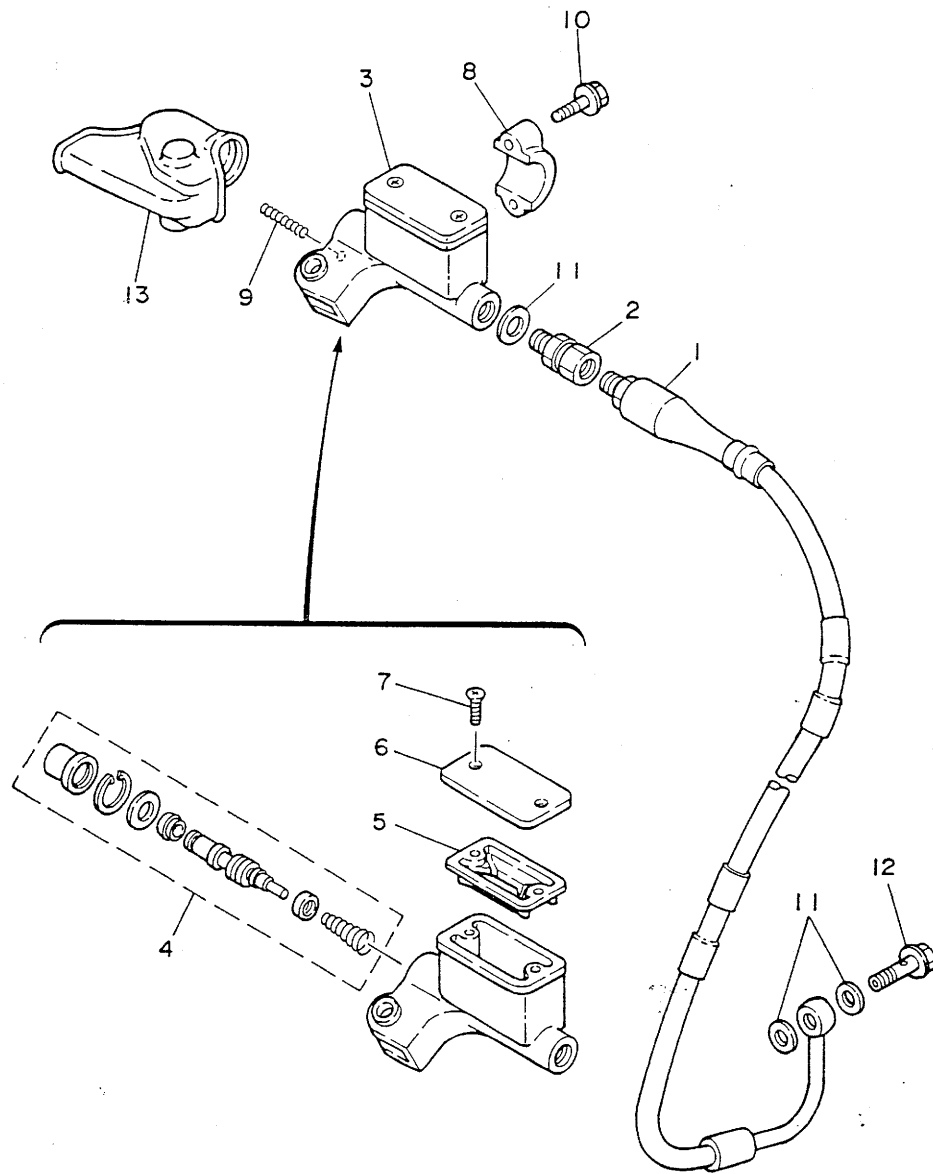

REF. NO.	PART NO.	DESCRIPTION	Q'TY	REMARKS
1	3SP-25872-00	HOSE, brake 1	1	
2	3LC-25885-00	JOINT	1	
3	3SP-25870-00	MASTER CYLINDER SUB ASSY	1	
4	3SP-W0041-00	.CYLINDER KIT, master	1	
5	56A-25854-00	.DIAPHRAGM, reservoir	1	
6	2VN-25852-00	.CAP, reservoir	1	
7	98706-04012	.SCREW, flat head	2	
8	56A-25867-00	BRACKET, master cylinder	1	
9	90501-061G2	SPRING, compression	1	
10	95026-06025	BOLT, flange	2	
11	90201-10118	WASHER, plate	3	
12	90401-10034	BOLT, union	1	
13	56A-26372-01	COVER, handle lever 1	1	

FIG. 31 STAND, FOOTREST

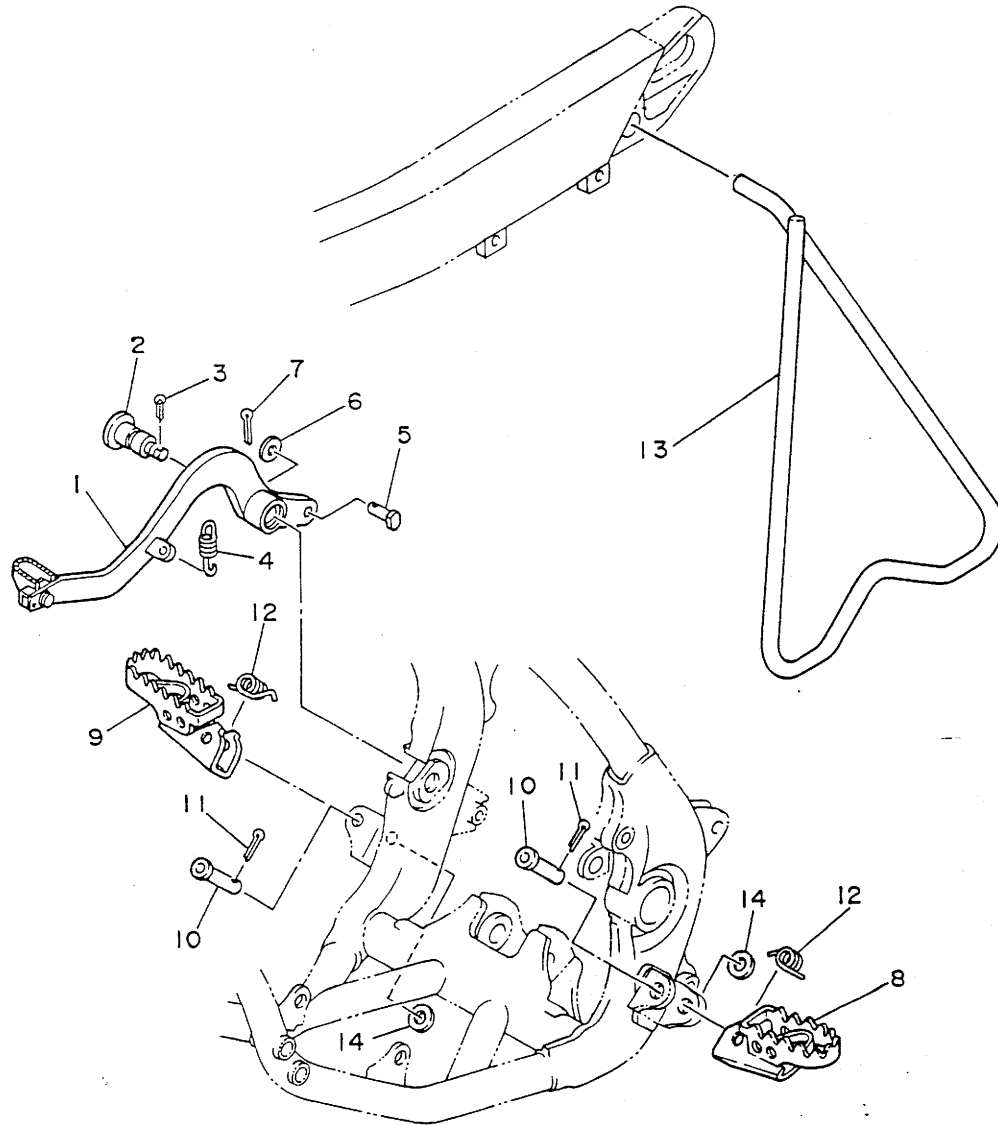

REF. NO.	PART NO.	DESCRIPTION	Q'TY	REMARKS
1	3JD-27200-01	PEDAL, brake	1	
2	3XJ-27217-00	BOLT	1	
3	91401-25015	PIN, cotter	1	
4	90506-14410	SPRING, tension	1	
5	90240-08120	PIN, clevis	1	
6	92901-08600	WASHER, plate	1	
7	91401-25015	PIN, cotter	1	
8	3SP-27411-00	FOOTREST 1	1	
9	3SP-27421-00	FOOTREST 2	1	
10	90240-10117	PIN, clevis	2	
11	91401-25015	PIN, cotter	2	
12	90508-28777	SPRING, torsion	2	
13	3SP-27311-00	STAND, side	1	
14	90201-10119	WASHER, plate	2	

FWD

FIG. 32 REAR MASTER CYLINDER

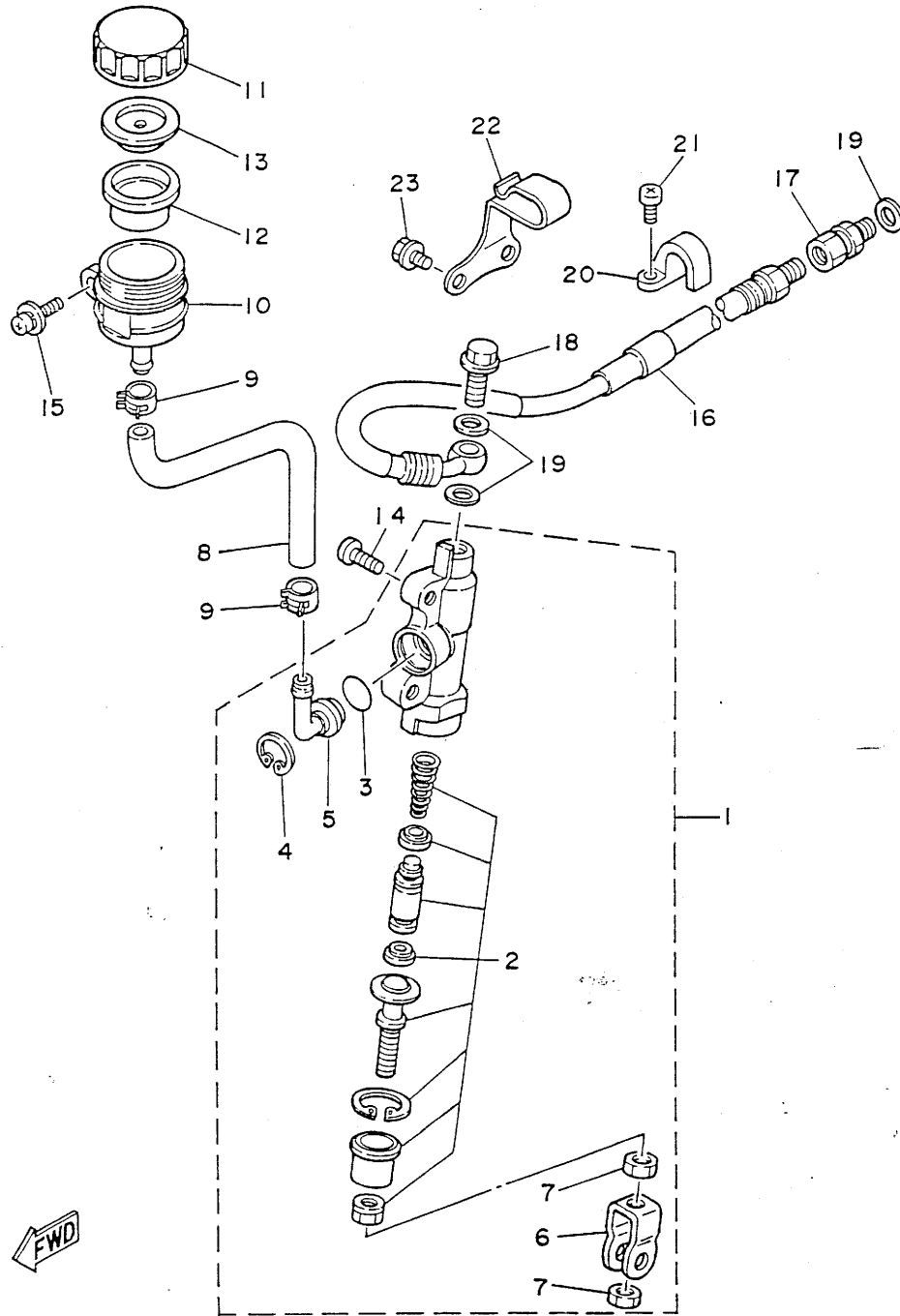

REF. NO.	PART NO.	DESCRIPTION	Q'TY	REMARKS
1	3SP-2583V-00	RR. MASTER CYLINDER ASSY.	1	
2	1FK-W0042-50	.CYLINDER KIT, master	1	
3	93210-15620	.O-RING	1	
4	2VN-25866-00	.CIRCLIP	1	
5	2VN-2582A-50	.JOINT	1	
6	3SP-27222-00	.JOINT	1	
7	95303-08600	.NUT	2	
8	3JD-25895-00	HOSE, reservoir	1	
9	90467-11044	CLIP	2	
10	2VN-25894-00	TANK, reservoir	1	
11	2VN-25852-50	CAP, reservoir	1	
12	2VN-25854-00	DIAPHRAGM, reservoir	1	
13	2VN-25855-00	BUSH, diaphragm	1	
14	92013-06016	BOLT	2	
15	90159-06056	SCREW, with washer	1	
16	3SP-25873-00	HOSE, brake 2	1	
17	3LC-25885-00	JOINT	1	
18	90401-10034	BOLT, union	1	
19	90201-10118	WASHER, plate	3	
20	2VM-25876-00	HOLDER, brake hose 2	1	
21	97780-50510	SCREW, tapping	2	
22	90462-12195	CLAMP	1	
23	95023-06008	BOLT	2	

FIG. 33 GENERATOR

REF. NO.	PART NO.	DESCRIPTION	Q'TY	REMARKS
1	3SR-85510-10	STATOR ASSY	1	
2	3SR-85550-20	ROTOR ASSY	1	
3	90149-06011	SCREW	2	
4	95311-10600	NUT	1	
5	90201-10774	WASHER, plate	1	

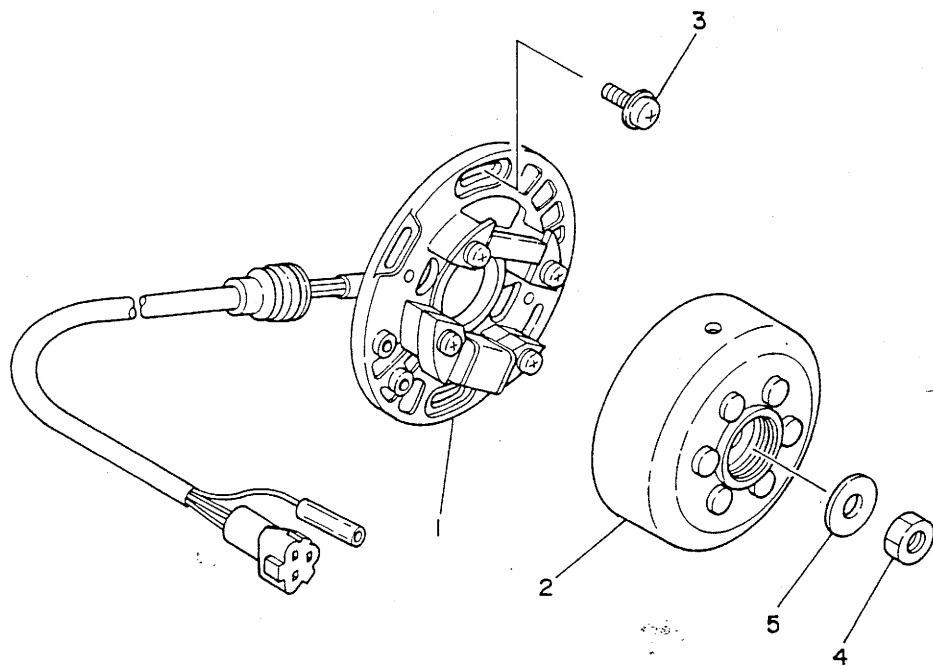

FWD

FIG. 34 HANDLE SWITCH. LEVER

REF. NO.	PART NO.	DESCRIPTION	Q'TY	REMARKS
1	38V-82911-00	HOLDER, lever 1	1	
2	38V-82913-00	HOLDER, lever lower 1	1	
3	23X-83912-00	LEVER 1	1	
4	90109-06799	BOLT	1	
5	95616-06100	NUT, u	1	
6	97006-05016	BOLT	2	
7	3SP-83922-00	LEVER 2	1	
8	90109-06577	BOLT	1	
9	95616-06100	NUT, u	1	
10	90149-06153	SCREW	1	
11	90170-06010	NUT	1	
12	23X-83976-00	SWITCH, handle 1	1	
13	437-83936-01	BAND, switch cord	2	

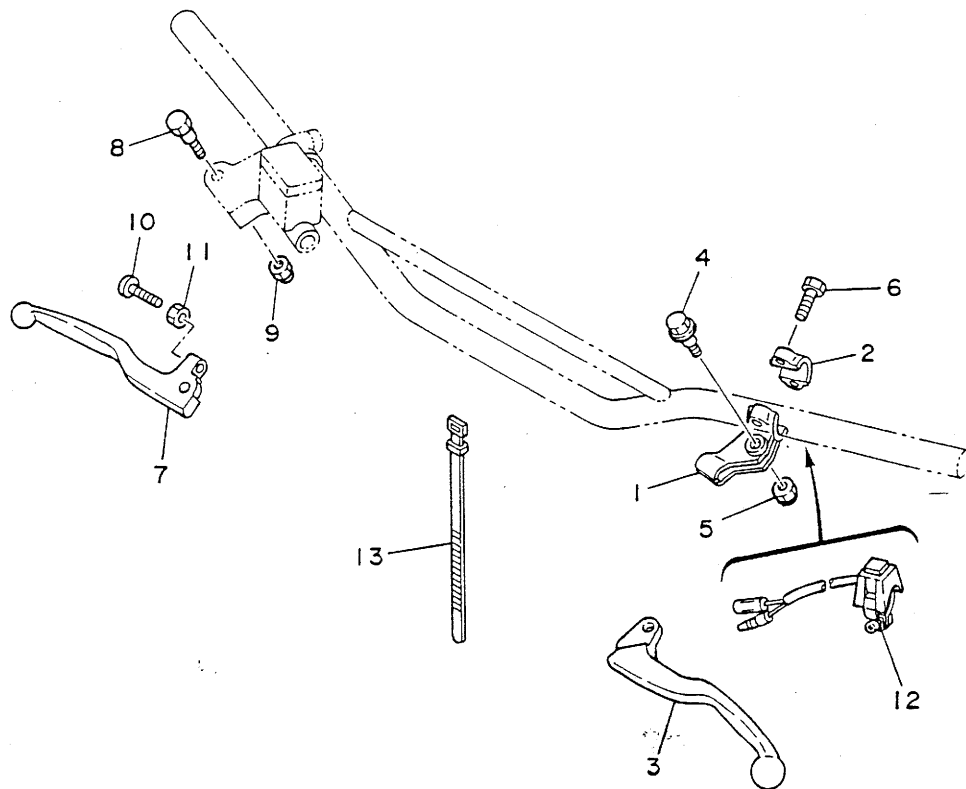

FWD

FIG. 35 ELECTRICAL 1

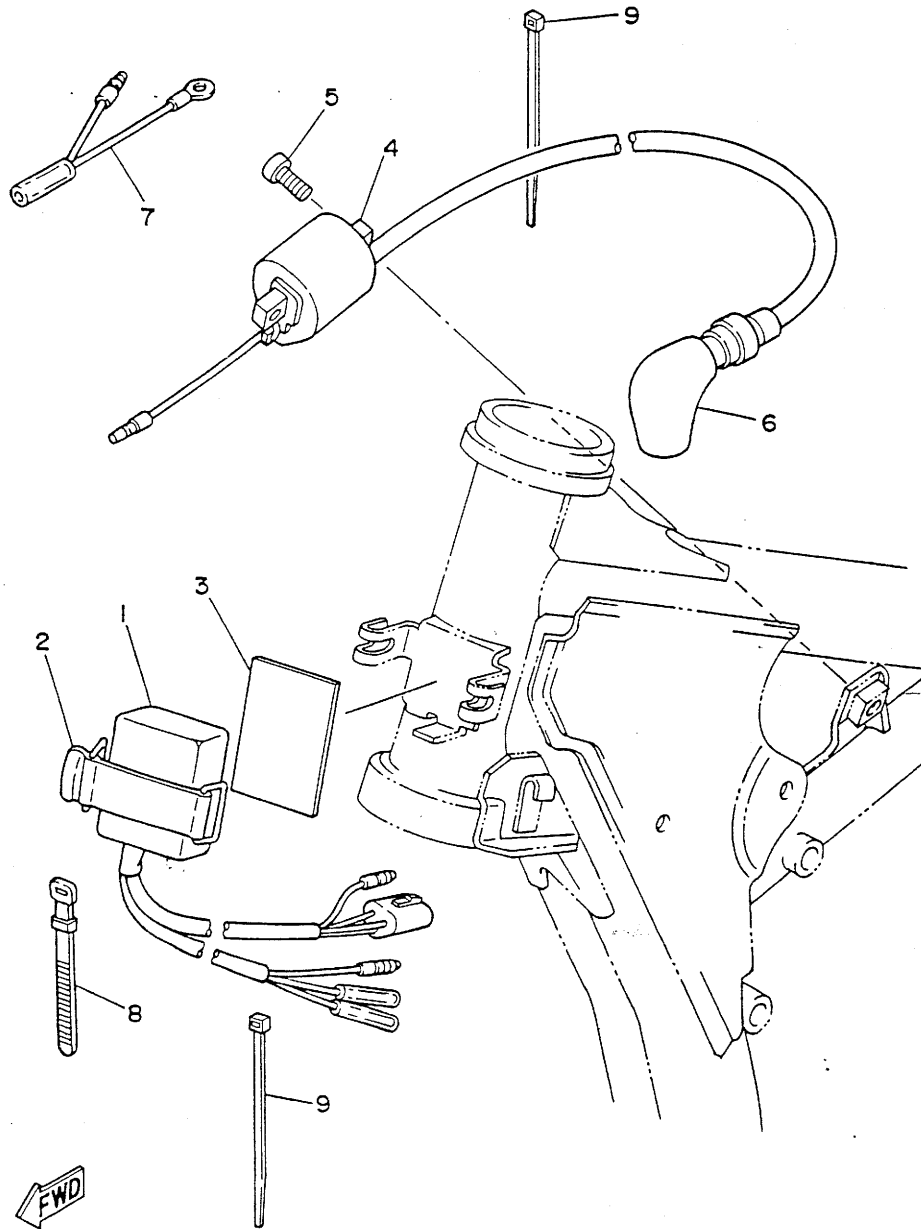

REF. NO.	PART NO.	DESCRIPTION	Q'TY	REMARKS
1	3SR-85540-10	C.D.I. UNIT ASSY	1	
2	21V-21376-00	BAND, tool	1	
3	2K7-85547-00	DAMPER	1	
4	3SR-82310-10	IGNITION COIL ASSY	1	
5	97021-06016	BOLT	2	
6	3R0-82370-20	PLUG CAP ASSY	1	UR
	2TV-82370-00	PLUG CAP ASSY	1	UR WITH NOISESUPPRESS
7	5X1-82519-01	WIRE, earth lead	1	
8	25G-83936-01	BAND, switch cord	1	
9	12R-82591-00	BAND	2	

FIG. 36 ALTERNATE (CHASSIS)

REF. NO.	PART NO.	DESCRIPTION	Q'TY	REMARKS
1	3XJ-22212-80	SPRING (K=4.4)	1	AP (SOFT)
	3XJ-22212-10	SPRING (K=4.8)	1	AP (HARD)
2	3XJ-23141-10	SPRING, front fork (K=0.350)	2	AP (SOFT)
	3XJ-23141-30	SPRING, front fork (K=0.380)	2	AP (HARD)
3	3XJ-23364-L0	COLLAR 2	1	UN

